

Notice

Hewlett-Packard to Agilent Technologies Transition

This documentation supports a product that previously shipped under the Hewlett-Packard company brand name. The brand name has now been changed to Agilent Technologies. The two products are functionally identical, only our name has changed. The document still includes references to Hewlett-Packard products, some of which have been transitioned to Agilent Technologies.



Agilent Technologies

**HP 85727A GSM Multiband Transmitter
Measurements Personality
User's Guide**



**HP Part No. 85727-90001
Printed in UK
February 1998**

Rev A.01.01
© Copyright Hewlett-Packard Ltd. 1998

Notice

The information contained in this document is subject to change without notice.

Hewlett-Packard makes no warranty of any kind with regard to this material, including but not limited to, the implied warranties of merchantability and fitness for a particular purpose. Hewlett-Packard shall not be liable for errors contained herein or for incidental or consequential damages in connection with the furnishing, performance, or use of this material.

**Regulatory
Information**

All regulatory information is in the calibration guide for your spectrum analyzer.

© Copyright Hewlett-Packard Ltd. 1998.
All Rights Reserved. Reproduction, adaptation, or translation without prior written permission is prohibited, except as allowed under the copyright laws.
Station Road, South Queensferry, Scotland, EH30 9TG, UK.

Hewlett-Packard Software License Agreement and Limited Warranty

IMPORTANT

Carefully read this License Agreement before downloading the software or operating the equipment with the software downloaded. Rights in the software are offered only on the condition that the Customer agrees to all terms and conditions of the License Agreement. Downloading the software or operating the equipment with the software downloaded indicates your acceptance of these terms and conditions. If you do not agree to the License Agreement, you may return the software media for a full refund.

License Agreement

In return for payment of the applicable fee, Hewlett-Packard grants the Customer a license in the software, until terminated, subject to the following:

Use

- Customer may use the software on one spectrum analyzer instrument.
- Customer may not reverse assemble or decompile the software.

Copies and Adaptations

- Customer may make copies or adaptations of the software
 - 1 for archival purposes, or
 - 2 when copying or adaptation is an essential step in the use of the software with a computer so long as the copies and adaptations are used in no other manner.
- Customer has no other rights to copy unless they acquire an appropriate license to reproduce, which is available from Hewlett-Packard for some software.
- Customer agrees that no warranty, free installation, or free training is provided by Hewlett-Packard for any copies or adaptations made by Customer.
- All copies and adaptations of the software must bear the copyright notices(s) contained in or on the original.

Ownership

- Customer agrees that they do not have any title or ownership of the software, other than ownership of the physical media.
- Customer acknowledges and agrees that the software is copyrighted and protected under the copyright laws.

Hewlett-Packard Software License Agreement and Limited Warranty

- Customer acknowledges and agrees that the software may have been developed by a third party software supplier named in the copyright notice(s) included with the software, who shall be authorized to hold the Customer responsible for any copyright infringement or violation of this License Agreement.

Transfer of Rights in Software

- Customer may transfer rights in the software to a third party only as part of the transfer of all their rights and only if Customer obtains the prior agreement of the third party to be bound by the terms of this License Agreement.
- Upon such a transfer, Customer agrees that their rights in the software are terminated and that they will either destroy their copies and adaptations or deliver them to the third party.
- Transfer to a U.S. government department or agency or to a prime or lower tier contractor in connection with a U.S. government contract shall be made only upon their prior written agreement to terms required by Hewlett-Packard.

Sublicensing and Distribution

- Customer may not sublicense the software or distribute copies or adaptations of the software to the public in physical media or by telecommunication without the prior written consent of Hewlett-Packard.

Termination

- Hewlett-Packard may terminate this software license for failure to comply with any of these terms provided Hewlett-Packard has requested Customer to cure the failure and Customer has failed to do so within thirty (30) days of such notice.

Updates and Upgrades

- Customer agrees not to export or re-export the software or any copy or adaptation in violation of the U.S. Export Administration regulations or other applicable regulations.

Limited Warranty

Software

Hewlett-Packard warrants for a period of **1 year** from the date of purchase that the software product will execute its programming instructions when properly installed on the spectrum analyzer instrument indicated on this package. Hewlett-Packard does not warrant that the operation of the software will be uninterrupted or error free. In the event that this software product fails to execute its programming instructions during the warranty period, customer's remedy shall be to return the measurement card ("media") to Hewlett-Packard for replacement. Should Hewlett-Packard be unable to replace the media within a reasonable amount of time, Customer's alternate remedy shall be a refund of the purchase price upon return of the product and all copies.

Media

Hewlett-Packard warrants the media upon which this product is recorded to be free from defects in materials and workmanship under normal use for a period of **1 year** from the date of purchase. In the event any media proves to be defective during the warranty period, Customer's remedy shall be to return the media to Hewlett-Packard for replacement. Should Hewlett-Packard be unable to replace the media within a reasonable amount of time, Customer's alternate remedy shall be a refund of the purchase price upon return of the product and all copies.

Notice of Warranty Claims

Customer must notify Hewlett-Packard in writing of any warranty claim not later than thirty (30) days after the expiration of the warranty period.

Limitation of Warranty

Hewlett-Packard makes no other express warranty, whether written or oral, with respect to this product. Any implied warranty of merchantability or fitness is limited to the **1 year** duration of this written warranty.

This warranty gives specific legal rights, and Customer may also have other rights, which vary from state to state or from province to province.

Exclusive Remedies

The remedies provided above are Customer's sole and exclusive remedies. In no event shall Hewlett-Packard be liable for any direct, indirect, special, incidental, or consequential damages (including lost profit) whether based on warranty, contract, tort, or any other legal theory.

Warranty Service

Warranty service may be obtained from the nearest Hewlett-Packard sales office or other location indicated in the owner's manual or service booklet.

HP 85727A GSM Multiband Transmitter Measurement Personality Documentation Description

The following guides are shipped with your GSM Multiband Transmitter Measurement Personality

HP 85727A GSM Multiband Transmitter Measurement Personality User's Guide

- This book - tells you how to use the GSM Measurement Personality. It also contains other spectrum analyzer measurement methods, specifications and characteristics, error messages and a glossary.

HP 85727A GSM Multiband Transmitter Measurement Personality Quick Reference Guide

- Tells you how to use the GSM Measurement Personality. It also contains other spectrum analyzer measurement methods. The small size makes it easy to carry with you when working at base station sites.

HP 85727A GSM Multiband Transmitter Measurement Personality Remote Programming Guide

- Tell you how to use the GSM Measurement Personality using the remote programming commands. Use this guide with the *HP 8590-E Series Programmer's Guide* shipped with your spectrum analyzer.

Notational Conventions

The display features six **softkeys** at the right-hand side of the display. A softkey executes a function defined by firmware or by software. The name of the function appears on the display next to the activating key.

This manual uses the following conventions:

FRONT PANEL KEY

An function name in a keycap symbol represents a labeled key physically located on the instrument. This key is referred to as either a **key** or a **hardkey**.

Softkey

A function name in screen-font indicates a softkey that either directly executes its function or provides access to a subset menu of softkeys.

Softkey ON OFF (ON)

A boxed word written in this typeface with the words ON and OFF can turn a function on or off. The underlined function is shown in brackets (parenthesis).

Softkey AUTO MAN (AUTO)

A boxed word written in this typeface with the words AUTO and MAN can either be auto-coupled or have its value manually changed. The underlined function is shown in brackets (parenthesis).

CRT Text

Unboxed text in a monospace font indicates any displayed text other than softkeys.

How to Use This Manual

If you have not installed your spectrum analyzer, or if you are not familiar with its operation refer to “Preparing for Use” in your *HP 8590E- Series Spectrum Analyzer User’s Guide*. It describes spectrum analyzer features and tells you how to make spectrum analyzer measurements.

If you are ready to use the capability of your HP 85727A GSM Multiband Transmitter Measurement Personality, turn to "chapter 1, Getting Started."

By internet, phone, or fax, get assistance with all your test and measurement needs.

Table 1-1 Contacting Agilent

Online assistance: www.agilent.com/find/assist

United States
(tel) 1 800 452 4844

Latin America
(tel) (305) 269 7500
(fax) (305) 269 7599

Canada
(tel) 1 877 894 4414
(fax) (905) 282-6495

Europe
(tel) (+31) 20 547 2323
(fax) (+31) 20 547 2390

New Zealand
(tel) 0 800 738 378
(fax) (+64) 4 495 8950

Japan
(tel) (+81) 426 56 7832
(fax) (+81) 426 56 7840

Australia
(tel) 1 800 629 485
(fax) (+61) 3 9210 5947

Asia Call Center Numbers

Country	Phone Number	Fax Number
Singapore	1-800-375-8100	(65) 836-0252
Malaysia	1-800-828-848	1-800-801664
Philippines	(632) 8426802 1-800-16510170 (PLDT Subscriber Only)	(632) 8426809 1-800-16510288 (PLDT Subscriber Only)
Thailand	(088) 226-008 (outside Bangkok) (662) 661-3999 (within Bangkok)	(66) 1-661-3714
Hong Kong	800-930-871	(852) 2506 9233
Taiwan	0800-047-866	(886) 2 25456723
People's Republic of China	800-810-0189 (preferred) 10800-650-0021	10800-650-0121
India	1-600-11-2929	000-800-650-1101

How to Order Manuals

Each of the guides listed above can be ordered individually. To order, contact your local HP Sales and Service Office.

Contents

1 Getting Started

Getting Started	16
About The HP 85727A GSM Multiband Transmitter Measurement Personality	17
Required Spectrum Analyzer Configuration	18
Getting Started	19

2 Making GSM Measurements

Making GSM Measurements	28
GSM Analyzer Mode	29
Configuring the test system for GSM Measurements	34
Making GSM Measurements	45
Mean Transmitted RF Carrier Power Measurements	46
Power Step Measurements	48
Combiner Tuning Measurements	50
Power vs. Time Measurements	52
Output RF Spectrum Measurements	55
Spurious Emissions Measurements	65
Intermodulation Attenuation Measurements	72
Intra-BSS Intermodulation Attenuation Measurements	81
Phase and Frequency Error Measurements	86
Monitor TX Band Measurements	90

Contents

3 Making Measurements in Spectrum Analyzer Mode

Making Spectrum Analyzer Measurements	94
Limit-Line Functions	95
Amplitude Correction Factors	110
Windows Display	117
Gate Utility (Option 105 only)	119
Time-Gating (Option 105 only)	123

4 If You Have a Problem

If You Have a Problem	146
Before Troubleshooting	147
Error Messages	151
Sales and Service Offices	163

5 Verifying Operation

Verifying Operation	166
Preparing for the Verification Tests	167
1. Verifying Gate Delay Accuracy and Gate Length Accuracy (Spectrum Analyzer Option 105 Only)	170
2. Verifying Gate Card Insertion Loss (Spectrum Analyzer Option 105 Only)	175
3. Verifying Phase Error Accuracy (Spectrum Analyzer Option 151 and 163 Combination)	178
4. Verifying Frequency Error Accuracy (Spectrum Analyzer Option 151 and 163 Combination)	182
Performance Verification Test Record	186

6 Specifications and Characteristics

General System Requirements 190
GSM System Description 191
GSM System Specifications 193
GSM System Characteristics 195
Spurious Emissions Characteristics 196
Intermodulation Attenuation Characteristics 198
Power Vs. Time 200
Phase and Frequency Error 201

Glossary

Index

Contents

Getting Started

Getting Started

What You'll Find In This Chapter

This chapter provides step-by-step procedures for setting up the HP 85727A GSM Multiband Transmitter Measurement Personality. It contains the following sections:

- Required equipment for making GSM measurements.
- Analyzer connections.
- Loading the measurement personality.
- Using the measurement personality memory card.

About The HP 85727A GSM Multiband Transmitter Measurement Personality

Welcome to the *HP 85727A GSM Multiband Transmitter Measurement Personality User's Guide*. The GSM Measurement Personality extends the functionality of your HP 8590E-Series spectrum analyzer by providing the specific measurements required for P-GSM900, E-GSM, R-GSM, DCS1800 and PCS1900 transmitter testing.

This User's Guide contains the following information:

- Chapters 1 and 2 tell you how to load the GSM Multiband Transmitter Measurement Personality and make GSM transmitter measurements.
- Chapter 3 shows you how to use standard spectrum analyzer functions which may be useful in trouble shooting faulty transmitters.
- Chapter 4 describes the error messages displayed by the GSM Multiband Transmitter Measurement Personality.
- Chapter 5 shows how to verify overall operation of the analyzer.
- Chapter 6 details the specifications and characteristics of the GSM Multiband Transmitter Measurement Personality.
- A Glossary of commonly used terms is also provided.

Required Spectrum Analyzer Configuration

The HP 85727A GSM Multiband Transmitter Measurement Personality can be used with an HP 8593E, HP 8594E, HP 8595E, and HP 8596E. The spectrum analyzer configuration is listed below. Critical specifications for equipment substitution are provided in Chapter 6, "Specifications and Characteristics".

- Required HP 8590E-Series spectrum analyzer options:
 - Option 004 Precision Frequency Reference (or an external 10 MHz reference)
 - Option 101 Fast Time Domain Sweeps (not required if option 151 is installed)
 - Option 105 Time-Gated Spectrum Analysis
- Additional HP 8590E-Series spectrum analyzer options required for phase and frequency error measurements (E-series spectrum analyzer only):
 - Option 151 Fast ADC & Digital Demodulator
 - Option 163 GSM/DCS Firmware for Option 151

NOTE:

Generic HP 8590E-Series spectrum analyzer front and back panel illustrations are used throughout this manual. Your analyzer's front and rear panels may be different, depending on the model number and options.

Getting Started

- 1 Connect the spectrum analyzer to an ac power source. Press **LINE** to turn the spectrum analyzer on.

NOTE:

In order for the spectrum analyzer to meet its specifications, allow it to warm up for 30 minutes after it is turned on. Do not attempt to make any calibrated measurements until the spectrum analyzer is warmed up. Be sure to calibrate the spectrum analyzer only *after* it has met operating temperature conditions.

The spectrum analyzer frequency and amplitude self-calibration routines are initiated by the **CAL FREQ & AMPTD** softkey in the menu located under the **CAL** key.

CAUTION:

Disconnect any cable attached to the rear panel GATE TRIGGER INPUT before beginning any calibration routines. Refer to the HP 8590E-Series spectrum analyzer operating manual for calibration information.

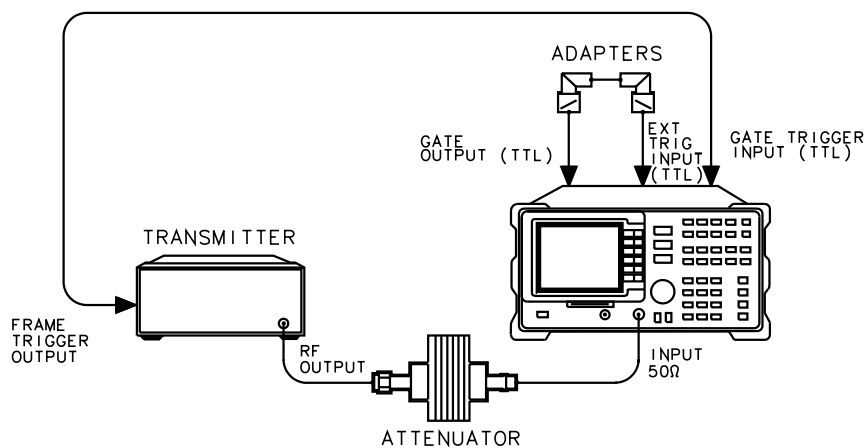

Figure 1 Front and Rear Panel Connections

NOTE:

“Triggering” on page 39 shows you more methods of connecting trigger sources

Getting Started

Getting Started

- 2 Attach the two right-angle BNC adapters (supplied with Option 105) to the GATE OUTPUT and the EXT TRIG INPUT connectors located on the rear panel of the spectrum analyzer. These adapters help to prevent BNC cable damage when the spectrum analyzer is set onto its rear feet.
- 3 Connect a BNC cable to the adapters on the GATE OUTPUT connector and the EXT TRIG INPUT connector.

NOTE:

During GSM measurements the cable connecting the GATE OUTPUT to the EXT TRIG INPUT can be left connected. This connection does not affect normal spectrum analyzer operation.

- 4 Connect A BNC cable from the EXT REF INPUT to either the 10 MHz REF OUTPUT or an external 10 MHz reference.
- 5 Connect an external TTL frame trigger signal to the GATE TRIGGER INPUT connector on the rear panel of the spectrum analyzer. The trigger signal needs to be a transistor-transistor logic (TTL) signal that generates a signal edge for every frame. The external trigger signal can be supplied by the unit under test or by an associated piece of test equipment that generates a frame trigger signal, such as the HP 85902A Burst Carrier Trigger or the HP 8922 GSM MS Test Set. This trigger signal is required for several GSM measurements. Refer to “Triggering” on page 39 in Chapter 2 for a further description.

CAUTION:

The maximum power that can be safely applied to the spectrum analyzer input is +30 dBm (1 watt). Most transmitters need a 20 dB to 30 dB attenuator between their output and the spectrum analyzer INPUT 50 Ω connector.

- 6 Connect the output of the transmitter-under-test through an appropriate attenuator or directional coupler to the INPUT 50 Ω connector on the front panel of the spectrum analyzer.

Loading the HP 85727A GSM Multiband Transmitter Measurement Personality

Completely purge the spectrum analyzer's user memory to make room for the GSM Multiband Transmitter Measurement Personality. Refer to the procedure below to purge, then load the GSM Measurement Personality.

Purging Spectrum Analyzer DLP Memory

- 1 Purge user memory by pressing **(CONFIG)** on the spectrum analyzer's front panel.
- 2 Press **MORE 1 OF 3**.
- 3 Press **Dispose User Mem**.
- 4 Press **ERASE DLP MEM** twice to purge the spectrum analyzer DLP memory.
- 5 Press **(PRESET)**.

Loading the GSM Multiband Transmitter Measurement Personality

- 1 Insert the HP 85727A GSM Multiband Transmitter Measurement Personality memory card into the spectrum analyzer's front-panel card reader. Match the card arrow with the arrow on the card reader slot.
- 2 Press **(RECALL)** on the spectrum analyzer's front panel.
- 3 Press **INTERNAL CARD** until **CARD** is underlined.
- 4 Press **CATALOG CARD**, then **CATALOG ALL**.
- 5 Make sure **dGSM** is highlighted, then select **LOAD FILE**. After a moment, the spectrum analyzer screen returns.
- 6 Press **(MODE)** on the spectrum analyzer to display the **SPECTRUM ANALYZER** key and the **GSM ANALYZER** key.
- 7 Press **GSM ANALYZER** to switch to the GSM analyzer mode and access the Main menu of the HP 85727A GSM Multiband Transmitter Measurement Personality.

The GSM Multiband Transmitter Measurement Personality is still retained in the spectrum analyzer's memory when the spectrum analyzer power is turned off or if you press **(PRESET)**.

Using the HP 85727A GSM Multiband Transmitter Measurement Personality

The GSM Multiband Transmitter Measurement Personality memory card should remain in the instrument's front-panel card reader. There are two reasons for this:

- Memory capacity restriction: The complete GSM Measurement Personality may require more memory than is available in your analyzer.
- Measurement limits files: Each standard requires a different limits file. The files are loaded from the card only when required.

When there is not enough memory for the complete GSM Measurement Personality, the following method is used:

- The GSM "core" program is copied into the spectrum analyzer's memory when the card is downloaded.
- When a different measurement set is selected from the Main menu, the last used measurement set may be purged. This is dependent on the amount of spectrum analyzer memory available. If the last used measurement is purged the new set is downloaded, indicated by the message **PLEASE WAIT, LOADING FILE...** This operation can take up to 50 seconds.

Once a measurement is selected and its menu appears, you can remove the card. If you want to access a different measurement set, reinsert the memory card into the card reader, otherwise, the message **INSERT HP 85727A MEMORY CARD & TRY AGAIN** is displayed.

NOTE:

Ensure the card is inserted in the card reader if you need to make measurements on different standards.

GSM Multiband Measurements

The following GSM measurements are available by pressing the appropriate Main menu key. Refer to Chapter 2, "Making GSM Measurements", for details on making these measurements.

- **Power** accesses the carrier power and power steps measurements.
- **Power vs Time** accesses the five different power versus time measurements.
- **Output RF Spectrum** accesses the RF spectrum due to modulation and RF spectrum due to switching transients measurements.
- **Spurious Emission** accesses the transmitter spurious and receiver spurious

- measurements.
- **Intermod** accesses the intermodulation attenuation and intermodulation intra-BSS measurements.
 - **Phase & Freq Err** accesses the phase and frequency error measurements. (Only available when spectrum analyzer option 163 is installed.)

Using the Additional RAM Card

An HP 82215A 128K RAM Card is included with the HP 85727A GSM Multiband Transmitter Measurement Personality shipment. This allows you to store setups to one card. A working copy of the GSM Multiband Transmitter Measurement Personality is included on this card.

When you are using the spectrum analyzer and the GSM Measurement Personality out in the field, keep the RAM card with the analyzer. Store the card labeled “HP 85727A GSM Multiband Personality” in a safe place. *Read the license agreement located at the beginning of this manual.*

Changing the Memory Card Battery

It is recommended that the memory card battery be changed every 2 years. The battery is a lithium commercial CMOS type battery, part number CR 2016.

NOTE:

The minimum lifetime of the battery (under ordinary conditions) is more than 2 years.

CAUTION:

The battery power enables the memory card’s memory to retain data. You can lose the data when the battery is removed. Replace the battery while the card is installed in a powered-up instrument.

The date that the memory card battery was installed is either engraved on the side of the memory card or written on a label on the memory card.

If the memory card does not have a label with the date that the battery was installed, use the date code engraved on side of the memory card. The date code engraved on the memory card consists of numbers and letters engraved in the black plastic on the side of the memory card. (See Figure 2). The first number indicates the year, the following two characters indicate the month, and the following number indicates the week in the month that the memory card battery was installed. For example, 8OC3 indicates the battery was installed in the third week in October in 1988.

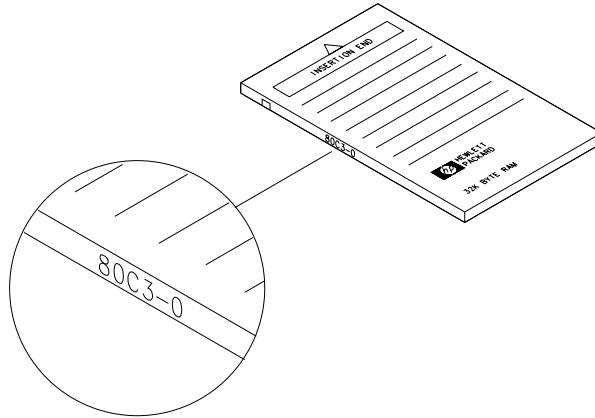

Figure 2 Memory Card Battery Date Code Location

Procedure to Change the Memory Card Battery

The battery is located beside the card's write-protect switch on the end opposite the connector.

CAUTION:

The battery power enables the memory card's memory to retain data. You can lose the data when the battery is removed. Replace the battery while the card is installed in a powered-up instrument.

- 1 Locate the groove along the edge of the battery clip. See Figure 3.
- 2 Gently pry the battery clip out of the card. The battery fits within this clip.
- 3 Replace the battery, making sure the plus (+) sign on the battery is on the same side as the plus (+) sign on the clip.
- 4 Insert the battery clip into the memory card, holding the clip as oriented in Figure 3. (Face the "open" edge of the clip toward the write-protect switch on the memory card.)
- 5 Write the date that the battery was replaced on the memory card label. This will help you to remember when the battery should be replaced.

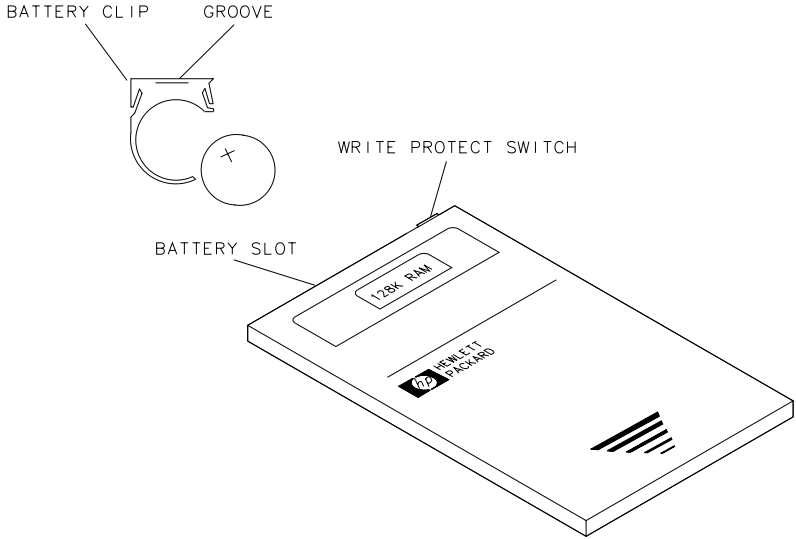

Figure 3 Memory Card Battery Replacement

Getting Started
Getting Started

Making GSM Measurements

Making GSM Measurements

What You'll Find In This Chapter

This chapter tells you how to configure and use the HP 85727A GSM Multiband Transmitter Measurement Personality. It is divided into the following sections:

- GSM Analyzer Mode.
- Configuring the test system.
- Making GSM Measurements.

GSM Analyzer Mode

Accessing GSM Analyzer Mode

Using the spectrum analyzer **(MODE)** key and associated softkeys allows you to switch between spectrum analyzer mode and GSM analyzer mode at any time. The instrument states for the two modes are completely independent. As a result, you can move quickly to the last measurement (and instrument state) of the previous mode. Refer to the information below:

- 1 Press **(MODE)** to display the mode menu. The keys **SPECTRUM ANALYZER** and **GSM ANALYZER** are displayed.

NOTE:

If the **GSM ANALYZER** key is not displayed, the program needs to be loaded into the spectrum analyzer's user memory. Refer to 'Loading the GSM Multiband Transmitter Measurement Personality' on page 21.

- 2 Once the mode menu is displayed, press **GSM ANALYZER**.
- 3 If **GSM ANALYZER** is not underlined, pressing the **GSM ANALYZER** key activates the GSM mode. The message **PLEASE WAIT...** is displayed as the initial state is set up.
- 4 If **GSM ANALYZER** is already underlined, pressing the **GSM ANALYZER** key displays the GSM Main menu, without changing any parameters.
- 5 When the GSM mode is active, **GSM900**, **DCS1800** or **PCS1900** is displayed above the softkey labels on the display.

GSM Analyzer Menu Access and Display Annotation

Accessing GSM Measurement Personality Menus

Once in the GSM analyzer mode, you can leave the GSM measurements menus and return to them at any time with the **(MODE)** key. Refer to the following methods:

- Press **(MODE)**, then **GSM ANALYZER** to return from spectrum analyzer menus to the GSM Main menu.
- Press **(MODE)**, **(MODE)** to return from spectrum analyzer menus to the GSM menu exited when you accessed a spectrum analyzer key.

GSM Measurement Personality Display Annotation

During GSM measurements annotation is displayed along the left-hand side of the screen. The annotation supplies information related to GSM measurements settings. Refer to the illustration below for an explanation of the annotation in this column.

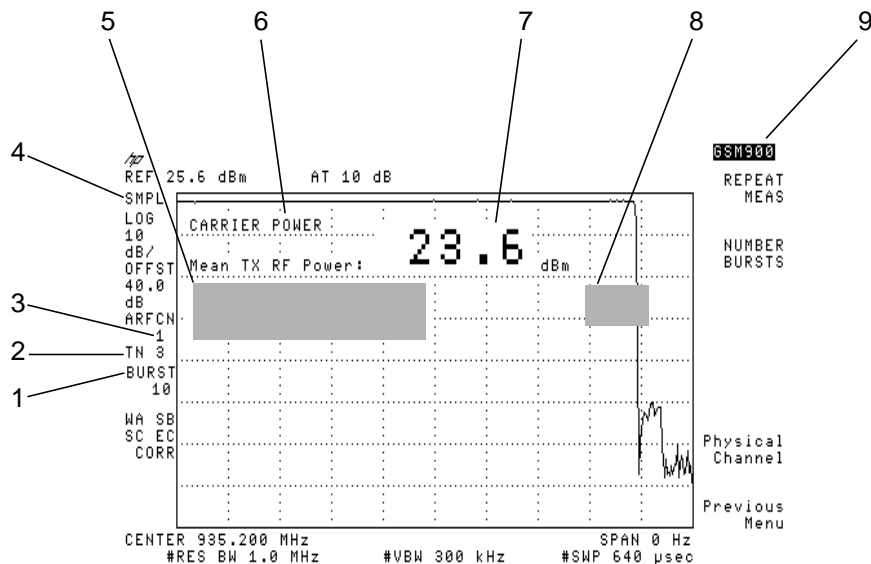

Figure 4 GSM Annotation

Item	Display Annotation	Description
1	BURST	Number of bursts to measure
2	TN	Timeslot number
3	ARFCN	Absolute RF channel number
4	GTSM	Detector in gated-sample mode
	GTPOS	Detector in gated-positive peak mode
	PEAK	Detector in peak mode
5	ACTIVE FUNCTION OR ERROR MESSAGE	Selected active function or measurement error messages
6	MEASUREMENT	The active measurement
7	MEASUREMENT RESULT	The measurement results
8	LIMIT LINE PASS/FAIL MESSAGE	Results of trace compared with limit line
9	GSM900 or DCS1800 or PCS1900	The current analyzer mode

Using Spectrum Analyzer Front-Panel Keys During GSM Operation

The menus of the GSM Multiband Transmitter Measurement Personality provide the softkeys that are normally needed for making measurements. Some spectrum analyzer front-panel keys, however, can provide useful, supplemental functions for GSM measurements. The more useful functions may be found under the following front-panel keys:

- **(MKR)** provides normal marker and marker delta functions. These may be used to obtain a readout of the trace values when the vertical scale represents amplitude. The readout may be in frequency or in time domains.
- **(COPY)** allows you to copy the screen to an HP-IB printer or a plotter that you select with the **(CONFIG)** key.
- **(FREQUENCY)** allows you to control the center frequency, start frequency, and stop frequency while you are making a band-measurement such as Spurious Emissions and Monitor TX Band.

The **(FREQUENCY)** key duplicates the GSM Physical Channel menu when making channel measurements like the Power vs. Time or Output RF Spectrum.

This ensures that the center frequency always matches the selected ARFCN. If a particular center frequency is required, use **CTR FREQ ARFCN=-1** under the **(FREQUENCY)** key, or **BMT ARFCN** to store the desired frequency for ARFCN=-1. This is the frequency used whenever an ARFCN is equal to -1 is selected.

- **(SPAN)** allows you to change the span of the displayed trace to optimize the view of measurement results.
- **(AMPLITUDE)** allows you to change the amplitude value of a displayed measurement result.
- **(BW)** allows you to adjust the resolution bandwidth or video bandwidth to optimize the view of measurement results.

Starting a new GSM measurement always sets the spectrum analyzer parameters for making that measurement. This is true whether you used spectrum analyzer menu keys or GSM menu keys to change settings. There is no need to press **PRESET GSM DLP** or **(PRESET)** before beginning a new measurement.

The spectrum analyzer **(SAVE)** and **(RECALL)** hardkeys are incompatible with the GSM-mode of operation.

Some of the spectrum analyzer softkey functions (not front-panel key functions) that are incompatible with GSM-mode operation are disabled during GSM mode of operation. The softkeys that are deleted from spectrum analyzer menus during GSM operation are listed below:

- **SCALE LIN**
- **AMPTD UNITS**
- **EXT PREAMP**
- **REF LVL OFFSET**
- **VAVG**
- **SAMPL PK**

All of the above softkeys are available in normal spectrum analyzer operating mode.

Configuring the test system for GSM Measurements

Most of the GSM measurements require that many of the following settings be pre-determined. Refer to the procedure below to enter the basic setup information.

Entering Configuration Information

NOTE:

GSM configuration values (under the Configuration menu) are not erased by pressing **(PRESET)**, **PRESET GSM DLE**, or by power cycling the spectrum analyzer.

- 1 Press **(MODE)** to access the **GSM ANALYZER** softkey.
- 2 Press **GSM ANALYZER** and wait for the Main menu to appear.
- 3 Press **Config** to access the Configuration menus.
- 4 Press **EXT ATTEN**. Use the data keys to enter the external attenuation value (in dB) used in the system. Press **(ENTER)** on the spectrum analyzer to terminate the entry.

The attenuation value should equal the total attenuation between the transmitter output and the spectrum analyzer input.

- 5 Press **PREAMP GAIN**. Use the data keys to enter a value (in dB). Press **(ENTER)** on the spectrum analyzer to terminate the entry.

NOTE:

A preamplifier is required for receive-band intermodulation and receive-band spurious emissions measurements. The preamplifier gain correction factor should take into account the gain of the preamplifier, insertion loss of the bandpass filter, and any cable loss.

- 6 Press **TRIG DELAY**. Enter the external trigger delay time using the data keys. Press **(ENTER)** on the spectrum analyzer. Enter a value of 0 if the external frame trigger occurs at the start of bit 0 in timeslot number 0.

A positive trigger delay shifts the displayed trace to the right, and a negative delay shifts the trace to the left. If the delay time is unknown, you can use the power versus time measurement to adjust the trigger delay time for relative measurements.

- 7 Press **TOTAL PWR SGL MULT** until SGL is underlined.

- 8 Press **512-810 DCS PCS**, to underline DCS if you want to tune to DCS1800 channels when an ARFCN in the range 512-810 is entered. If you want to tune to PCS1900 channels with an ARFCN in the 512-810 range, press **512-810 DCS PCS** to underline PCS.
- 9 Press **More 1 of 3**, then **SFH ON OFF** until OFF is underlined to disable slow frequency hopping mode. If SFH is enabled, extra sweeps and longer sweeps are taken. Disable SFH (underline OFF) for GSM measurements unless a hopping signal is being measured.
- 10 Press **Main Menu** to return to the Main menu.

Entering Physical Channel Information

- 1 In GSM analyzer mode, press **Physical Channel** in the Main menu.
- 2 Press **TX MS BS** until you underline either MS for mobile station testing or BS for base station testing. The TX or transmit band of either a mobile station or base station will be measured.

The following conditions are affected by the mobile- or base-station settings:

- The center frequency set by ARFCN.
- The start and stop frequency of the monitor-band mode.
- The output RF spectrum swept-mode limit lines.
- The frequencies and limits of the spurious emissions tests.
- The frequencies and limits of the intermodulation test.

- 3 Press **ARFCN** and use the data keys to enter the absolute RF channel number (ARFCN) of the carrier to be measured, then press **(ENTER)** on the spectrum analyzer. You can also use the step keys and step the ARFCN one channel at a time.

NOTE:

To make a “channel” measurement at a center frequency other than that specified by a channel number, select **ARFCN** and use the data keys to enter -1 . Then select **B M T ARFCN**, **CTR FREQ ARFCN=-1** and use the data keys to enter the frequency of interest.

- 4 Press **TIMESLOT NUMBER** and use the data keys to enter the timeslot number (TN) to measure, then press **(ENTER)** on the spectrum analyzer.
- 5 Press **Auto Function**. Follow by pressing either **AUTO ARFCN**, and **AUTO TN**, or press **AUTO ARFCNTN**. Pressing **AUTO ARFCNTN** is like pressing **AUTO ARFCN**, then **AUTO TN**. These functions automatically set the ARFCN or TN to the channel number or timeslot number having the highest power level. If multiple carriers are present, they need to be separated by at least 1 MHz.
- 6 Press **Main Menu** or **Previous Menu** to return to the Main menu.

NOTE:

Only the mean carrier power, power vs. time, and output RF spectrum measurements require the ARFCN and TN to be specified. All measurements require that **TX MS BS** to be determined.

The remaining Physical Channel menu keys are normally left in their preset conditions.

Preset States and Default Conditions

Table 1 GSM Measurement Preset States

Preset Values			
	GSM900	DCS1800	PCS1900
ARFCN	1	512	512
Bottom ARFCN	1	512	512
Middle ARFCN	62	699	661
Top ARFCN	124	885	810
Start Frequency	924 MHz	1804 MHz	1929 MHz
Stop Frequency	961 MHz	1881 MHz	1989 MHz
Span	37 MHz	77 MHz	60 MHz
Note:	The analyzer presets to the GSM standard in use immediately before initiating PRESET.		
TX MS BS	BS (base station)		
Timeslot Number	0		
Number Bursts	1		
CF Step	200 kHz		
Frequency Offset	0 Hz		
Reference Level	30 dBm + External Attenuation		
Log Scale	10 dB/div		
Amplitude Units	dBm		
Res BW	100 kHz		
Video BW	100 kHz		
Video Averaging	off		
Sweeptime	2 s		
Detector	peak		
Sweep	continuous		
Trigger Mode	free run		
Markers	off		

Table 1 GSM Measurement Preset States

Preset Values	
A – B → A	off
Trace A	clear-write
Trace B	store-blank
Trace C	store-blank
Threshold Level	off
Display Line Level	off
Limit Line Testing	off
Graticule	on
For HP 8590E Series with Option 163:	
Start bit	0
End bit	147
Graph scale	20°
Measurement calibration	on
Burst type	normal
Color	automatic
Synchronization	midamble
Frequency error offset	0 Hz
Spur Test	off

Table 2 Measurement Default Conditions

Configuration Default Values	
Preamp Gain	0 dB
Trigger Delay	0 μs
Trigger Polarity	positive
External Attenuation	0 dB
SFH	off
Frame Structure	156.25 bits/timeslot
Total Power Mode	Single
Total Power Value	0 dB

Triggering

The triggering connection is required for some measurements. The trigger signal needs to be supplied by the unit under test or by an associated piece of test equipment. The following methods can be used to generate a frame trigger signal.

NOTE:

It is essential that an external trigger signal is applied for phase and frequency error measurements otherwise the spectrum analyzer does not complete the measurement. Once the external trigger signal is applied the spectrum analyzer will continue to function correctly.

Using the unit under test

The spectrum analyzer EXT TRIG INPUT (TTL) and GATE OUTPUT (TTL) on the rear panel should be connected together. The source Frame Trigger Output should be connected to the spectrum analyzer rear panel GATE TRIGGER INPUT (TTL). Figure 5 shows these connections.

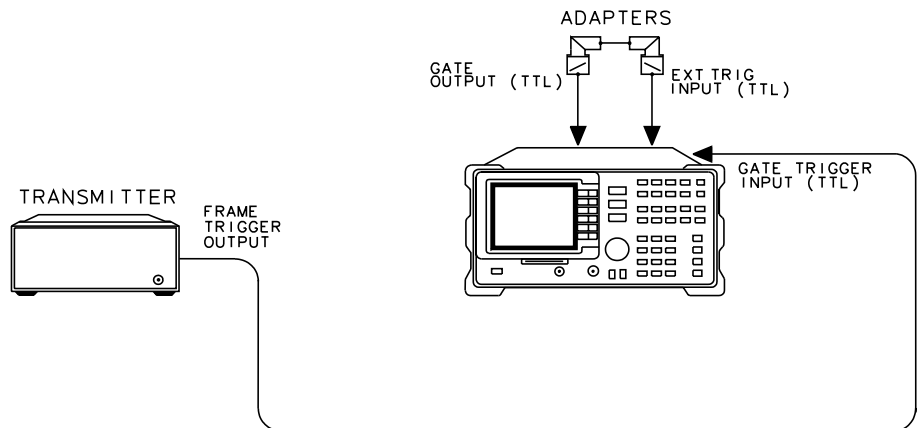

Figure 5 Triggering Connections using the Unit Under Test

Using the HP 85902A

The spectrum analyzer EXT TRIG INPUT (TTL) and GATE OUTPUT (TTL) on the rear panel should be connected together. The HP 85902A TRIG OUT (TTL) should be connected to the spectrum analyzer rear panel GATE TRIGGER INPUT (TTL). Figure 6 on page 40 and Figure 7 on page 41 show two methods of using the HP 85902A to provide the trigger signal.

CAUTION:

To avoid spectrum analyzer damage an external attenuator may be required.

The total power applied to the spectrum analyzer INPUT 50Ω can not exceed +30 dBm. If the input exceeds +30 dBm, spectrum analyzer damage may result.

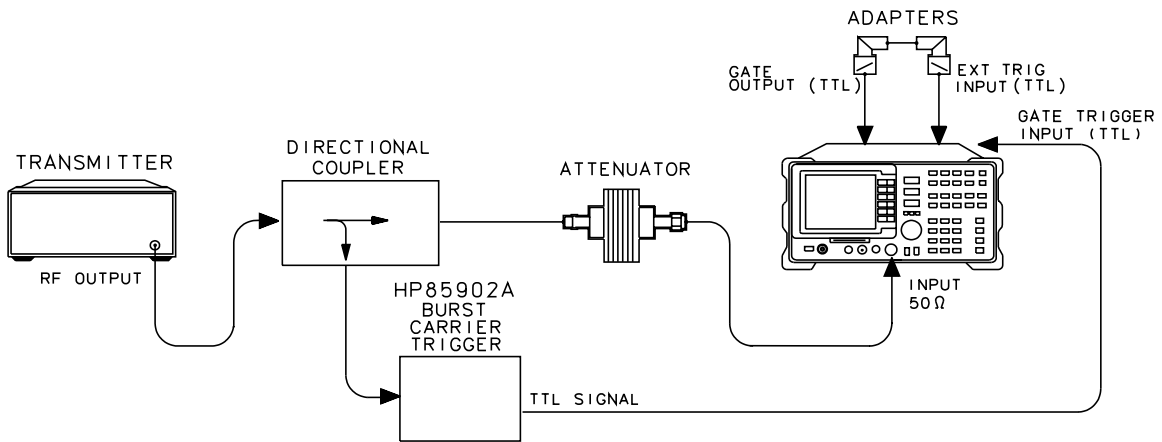

Figure 6 Triggering Connections using the HP 85902A and a Directional Coupler

NOTE:

Ensure the Transmitter is configured to transmit only once per time frame.

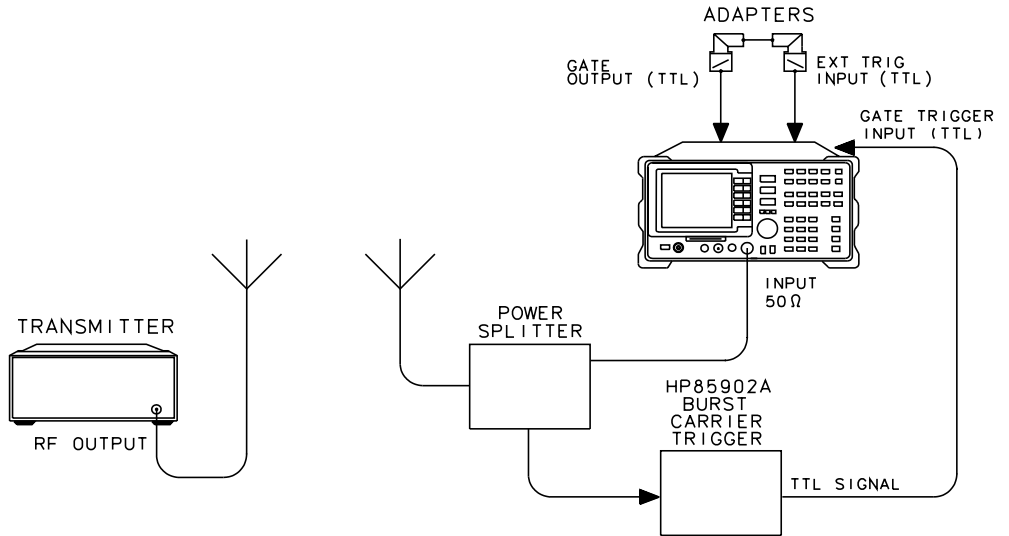

Figure 7 Triggering Connections using the HP 85902A and a Power Splitter

Using the HP 8922

The spectrum analyzer EXT TRIG INPUT (TTL) and GATE OUTPUT (TTL) on the rear panel should be connected together. The spectrum analyzer rear panel GATE TRIGGER INPUT (TTL) should be connected to pin 24 (G_EXT_TRIG) and pin 2 (Ground) of the HP 8922 SYSTEM BUS. You will need to supply your own cable to make this connection.

The HP 8922 frame clock, `g_ext_trig`, can be enabled in the HP 8922 SERVICE Screen. From the HP 8922 SERVICE Screen select `g_ext_trig` in the **Latch** field and 305 in the **value** field. To activate the clock, select `g_ext_trig_enable` in the **Latch** field and 1 in the **value** field.

Refer to Figure 8 on page 43 for the setup required to trigger the spectrum analyzer using the HP 8922.

CAUTION:

To avoid spectrum analyzer damage an external attenuator may be required.

The total power applied to the spectrum analyzer INPUT 50Ω can not exceed +30 dBm. If the input exceeds +30 dBm, spectrum analyzer damage may result.

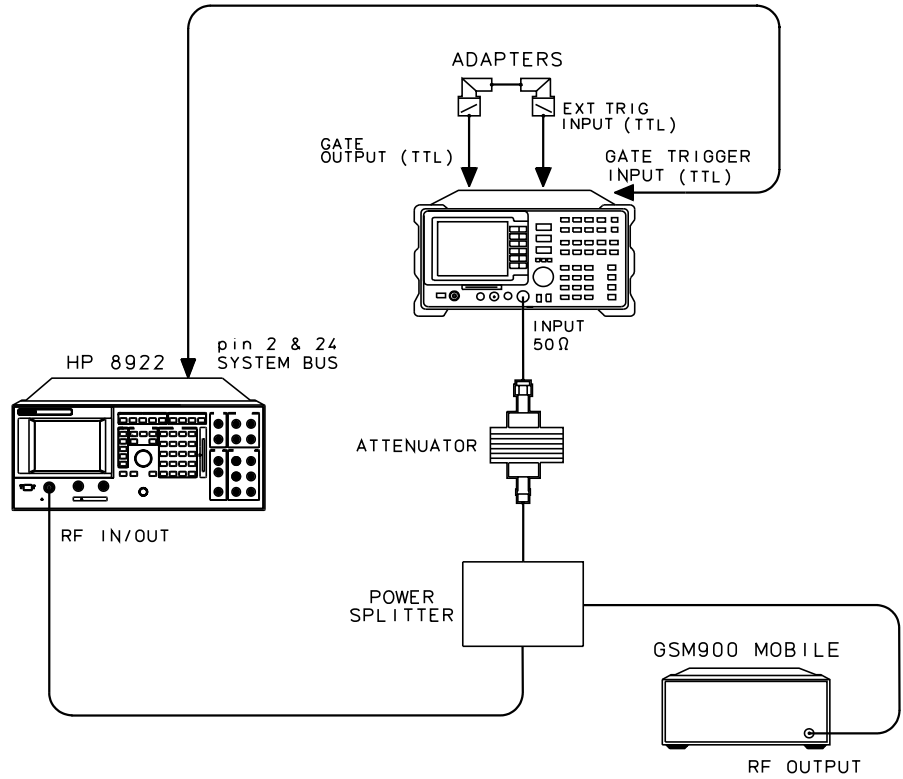

Figure 8 Triggering Connections using the HP 8922

**Using the spectrum analyzer internal trigger
(Option 151 only)**

The spectrum analyzer EXT TRIG INPUT (TTL) and GATE OUTPUT (TTL) on the rear panel should be connected together. The spectrum analyzer FRAME TRIGGER OUTPUT (TTL) and GATE TRIGGER INPUT (TTL) on the rear panel should also be connected together. Figure 9 shows the connections.

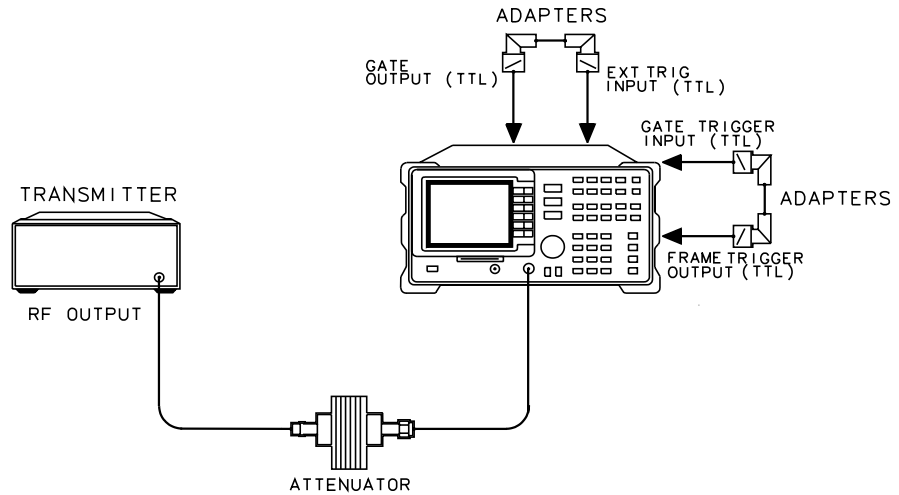

Figure 9 Connections using the spectrum analyzer internal trigger

Making GSM Measurements

This section contains descriptions and procedures for the measurements available from the GSM Multiband Transmitter Measurement Personality. Ensure you have completed the analyzer configuration before proceeding.

Using the GSM Multiband Transmitter Measurement Personality Card

The HP 85727A GSM Multiband Transmitter Measurement Personality memory card must remain inserted in the instrument's front-panel card reader. The entire personality may require too much of the spectrum analyzer's memory and measurement limit files are loaded from the card when the analyzer is tuned from one standard to another.

Mean Transmitted RF Carrier Power Measurements

Description

The mean transmitted carrier power measurement determines the average power for a specified ARFCN and TN. A zero span measurement is made and the average power level during the useful part of the burst is measured, then displayed.

SFH mode is available for this measurement.

An external frame trigger signal is required for this measurement.

Test Procedure

- 1 Enter all the information as specified in the “Configuring the test system for GSM Measurements” and “Entering Physical Channel Information” sections of this chapter. For this test, specifically enter the desired ARFCN and TN via the Physical Channel menu.
- 2 Press **Power** in the Main menu, then **CARRIER POWER**. The program sets the spectrum analyzer to the GSM specified values for the measurement. The spectrum analyzer reference level is automatically set to the optimum value based on the measured carrier power level. A display of the mean carrier power is updated at the end of each sweep. After the selected number of bursts are measured, the trace is paused and the final result is displayed.

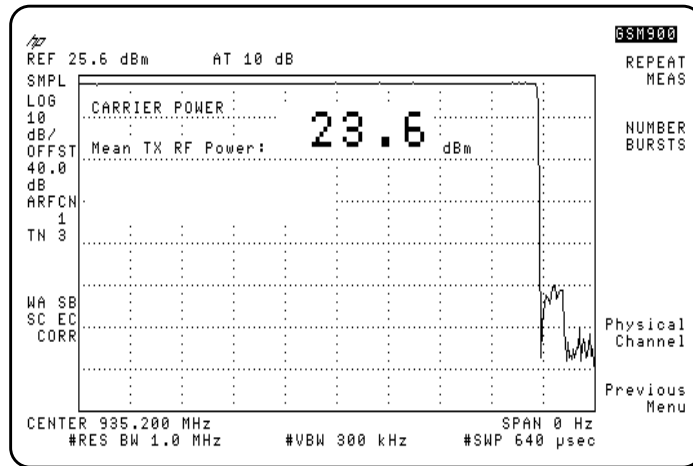

Figure 10 Example of Carrier Power Measurement Result

- Press **NUMBER BURSTS** and enter a new value if you want to change the number of bursts to be averaged. If **NUMBER BURSTS** is set to 1, the carrier power is continually measured. Changing the value automatically repeats the measurement.
- Press **Physical Channel**, then press either **ARFCN** or **TIMESLOT NUMBER** and enter a new value if you want to change either of these settings. Press **Previous Menu** to return to the carrier power menu.
- Press **REPEAT MEAS** to restart the measurement after making any settings changes or just to make the measurement again. You can also change parameters such as the resolution bandwidth, then repeat the measurement at the new resolution bandwidth setting by pressing **REPEAT MEAS**. Return to the current GSM menu from the spectrum analyzer keys by pressing **(MODE)**.

Power Step Measurements

Description

This measurement uses long sweep times to display the different power steps resulting from adaptive power control. Power step measures the dynamics of the power step changes. Use the more accurate mean carrier power measurement to make power measurements on carriers with a static power level. The power step measurement checks the maximum power of all 8 timeslots.

SFH mode is available for this measurement.

An external frame trigger signal is *not* required for this measurement.

Test Procedure

- 1 Enter all the information as specified in the “Configuring the System for GSM Measurements” and “Entering Physical Channel Information” sections of this chapter. For this test, specifically enter the desired ARFCN via the Physical Channel menu.
- 2 Press **Power** to access the Power measurements menu keys.
- 3 Press **CARRIER POWER** to measure the carrier power at the maximum transmitter output. Make this measurement first to set the spectrum analyzer reference level for the power steps measurement.
- 4 Press **Previous Menu**.
- 5 Press **POWER STEPS**. The program sets the spectrum analyzer to the appropriate values for the measurement.
- 6 Press **SWEEP CONT SGL** and underline **SGL** to take one sweep, or underline **CONT** for continuous sweep mode.
- 7 Step the power of your GSM transmitter under test.
- 8 If desired, you can enter a new sweep time or use the delta markers to evaluate the power steps measurement further. Use the procedure below:
 - Use the spectrum analyzer (**SWEEP**) key to enter a new sweep time. Use the following steps to evaluate the power steps at a new sweep time:

- a Change the sweep time by pressing the spectrum analyzer **(SWEEP)** key. Enter a new sweep time, then press an appropriate units (seconds) key.

NOTE:

The sweep time needs to be greater than or equal to 2 seconds.

- b Press **(MODE)**, **(MODE)** to return to the current GSM menu from the spectrum analyzer keys.
- c If CONT is underlined in the **SWEEP CONT SGL** key, the new sweep time is automatically used. Press **REPEAT MEAS** to make the power steps measurement at the new sweep time if SGL is underlined.
- Use the delta markers to determine the power and time between two points of the displayed trace. Use the procedure below:
 - d Press **MARKER DELTA** in the GSM menu to activate the markers.
 - e Position the marker on the reference point of interest. Press **MARKER DELTA** again.
 - f Rotate the knob to locate the marker on a second point of the trace. The power level and time difference between the two markers is displayed.
 - g To turn marker off press **(MKR)**, **MARKER 1 ON/OFF**, **(MODE)**, **(MODE)**.

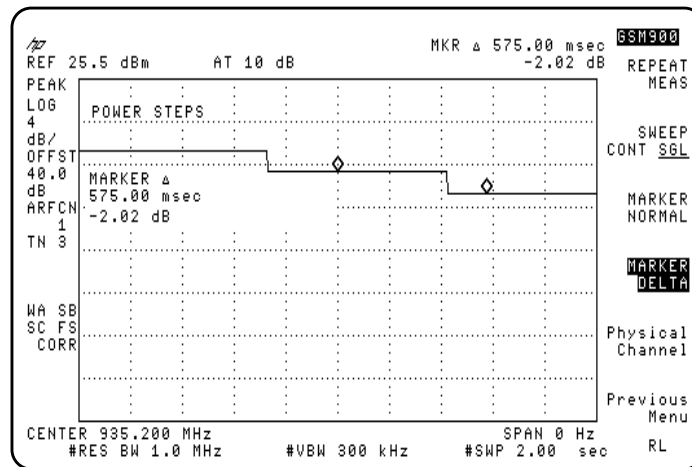

Figure 11 Example of Power Steps Measurement Results

- 9 Press **Physical Channel**, then press **ARFCN** and enter a new value if you want to change this setting.
- 10 Press **Previous Menu** to return to the measurement menu.

Combiner Tuning Measurements

Description

This measurement allows the output power from several base station transmitters to be viewed so that the output power from each transmitter can be matched.

The base station transmitters should be set to produce a CW (not pulsed) signal.

The frequency spectrum of the full transmit band for base stations is displayed.

Marker lines are placed on the maximum carrier, another on the minimum carrier and a third on the threshold. The measurement shows numerically the power of the maximum carrier detected, and the power difference between the maximum and minimum carriers.

The following softkeys are shown under the combiner tuning measurement: **REF LVL**, **SCALE LOG**, **START FREQ**, **STOP FREQ** and **Previous Menu**. To ensure correct power calculations, all of the carriers must be at least 1 MHz apart.

An external frame trigger is *not* required for this measurement.

Test Procedure

- 1 Enter all the information as specified in the “Configuring the test system for GSM Measurements” and “Entering Physical Channel Information” sections of this chapter. Note that **TX MS BS** must be set to BS.
- 2 Press **Power** in the Main menu, then **COMBINER TUNING**. The spectrum analyzer reference level is automatically set to the optimum value based on the measured carrier power level.
- 3 If required the spectrum analyzer settings can be adjusted. Press **REF LVL** to adjust the reference level, **SCALE LOG** for the amplitude scale, **START FROM** for the start frequency, and **STOP FREQ** for the stop frequency.
- 4 Adjust the output power of the transmitters. As the outputs are adjusted for equal amplitude, the distance between the upper and lower marker lines (Δ Pwr) will decrease.

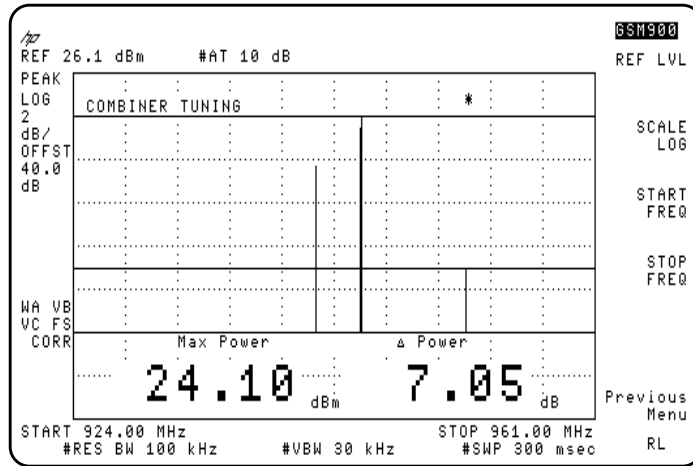

Figure 12 Example of Combiner Tuning Measurement

Power vs. Time Measurements

Description

The power versus time measurement analyzes the amplitude profile and timing of the burst signal. Two of the five power versus time formats available with this GSM Measurement Personality are full frame and full timeslot. The other three formats are listed under sub-timeslot and are top 10 dB (of the GSM pulse), rising edge, and falling edge.

When any of the power versus time measurements are selected, the program sets the spectrum analyzer to the specified values for the measurement. The spectrum analyzer reference level is automatically set to the optimum value based on the measured carrier power level. The transmitter signal is then compared to a limit-line template, with limits derived as a function of the mean transmitted carrier power level. Limit pass or fail results are displayed at the completion of the measurements.

SFH mode is available for this measurement.

An external frame trigger signal is required for this measurement.

Test Procedure

- 1 Enter all the information as specified in the “Configuring the test system for GSM Measurements” and “Entering Physical Channel Information” sections of this chapter. For this test, specifically enter the desired ARFCN and TN via the Physical Channel menu.
- 2 Press **Power vs Time** in the Main menu.
 - Press **P vs T FRAME** to activate the full frame measurement.
 - Press **P vs T TIMESLOT** to activate the full timeslot measurement.
 - Press **P vs T SUB TS** to access the next three measurement formats.
 - Press **P vs T TOP 10dB** to measure the top 10 dB portion of the GSM burst.
 - Press **P vs T RISING** to measure the rising edge of the GSM burst.
 - Press **P vs T FALLING** to measure the falling edge of the GSM burst.

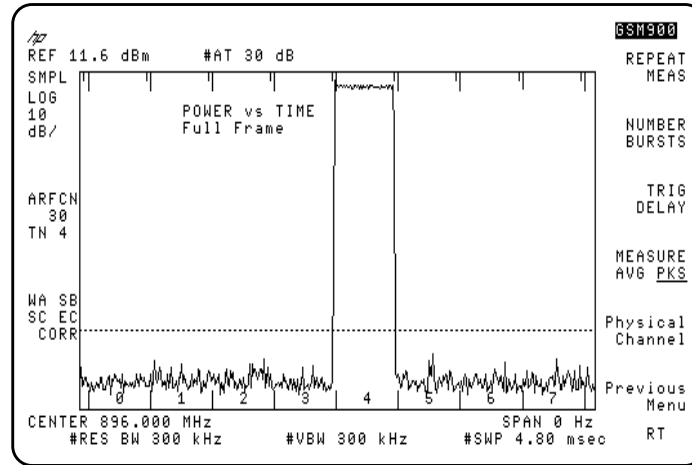

Figure 13 Example of Power vs. Time, Full-Frame Measurement Result

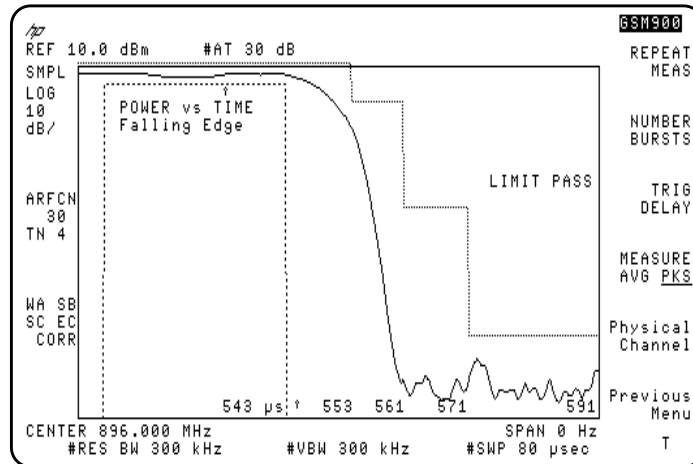

Figure 14 Example of Power vs. Time, Falling-Edge Measurement Result

NOTE:

For the Power vs. Time Falling measurement, the “rising edge” viewed during the first 4 μ s is due to the limitations of the delayed trigger hardware. It is *not* the rising edge of the burst. Data viewed after the first 4 μ s until the end of the 80 μ s sweep is valid.

- 3 Use the following keys to further modify the power vs. time test parameters for any of the power vs. time measurement formats:
 - a Press **NUMBER BURSTS** to change the number of bursts to be averaged, if desired. The preset value is 1 which allows the power versus time signal to be continually measured. For values greater than 1, the sweep stops after the selected number of bursts is reached. Changing the value automatically repeats the measurement.
 - b Press **TRIG DELAY** to change the trigger delay value, if desired. Use the keys or the knob to enter a new value, then terminate with μ s.

A positive trigger delay shifts the displayed trace to the right, and a negative delay shifts the trace to the left. If the delay time is unknown, you can use the power versus time measurement to adjust the trigger delay time for relative measurements.
 - c Press **MEASURE AVG PKS** and underline AVG to activate the averaging measurement. Underline PKS to activate the minimum-peaks and maximum-peaks measurement. This selection only applies when **NUMBER BURSTS** is greater than 1.
 - d Press **Physical Channel**, then press either **ARFCN** or **TIMESLOT NUMBER** and enter a new value if you want to change either of these settings.
 - e Press **Previous Menu** to return to the measurement menu.
- 4 Press **REPEAT MEAS** to restart the measurement after making any settings changes or just to make the measurement again. You can also change parameters such as the resolution bandwidth, then repeat the measurement at the new resolution bandwidth setting by pressing **REPEAT MEAS**. Return to the current GSM menu from the spectrum analyzer keys by pressing **(MODE)**, **(MODE)**.

Output RF Spectrum Measurements

Description

The output RF spectrum measurements determine the spectral energy emitted into the adjacent channels. The measurements are divided into two main groups. One group measures the RF spectrum that is due to the 0.3 GMSK modulation and the other measures the RF spectrum that is due to switching transients (burst ramping). In addition, you can measure the RF spectrum due to modulation in the RX band.

SFH mode is available for Output RF Spectrum Swept Measurements.

An external frame trigger signal is required for the spectrum due to modulation measurement, but is *not* required for the RF spectrum due to transient measurements.

GSM Specifications specify a test method where the spectrum analyzer, in zero span, is tuned to specified offsets from the carrier frequency. The HP 85727A GSM Multiband Transmitter Measurement Personality identifies this as single-offset or multiple-offset modes. The measurement made in these two modes is the same, except that the multiple-offset mode automatically makes the measurement at all the specified offset frequencies and lists the results in a table at the end of the measurement.

In these modes, the following conditions are met:

- In the output RF spectrum due to modulation measurement, the average value during at least 40 bits between bit 87 and 132 (approximately equivalent to the 50% to 90% portion of the burst, excluding midamble) is retained. The vertical lines mark the section of the burst over which the measurement is made. If multiple bursts are examined, an average of the average values is calculated. The relative power (difference between the average power of the burst at zero offset and the average power of the burst at the indicated offset) and the absolute power are displayed.
- In the output RF spectrum due to transients, the peak value of the burst is retained. If multiple bursts are examined, then the maximum of the peak values is retained. The relative power (difference between the peak power of the burst at zero offset and the peak power of the burst at the indicated offset) and the absolute power are displayed.

Another measurement method is the swept-frequency mode which uses the Option 105 time-gated spectrum analysis card. During this measurement, the GSM Measurement Personality sweeps the spectrum analyzer, with the gate turned on only for the desired portion of the burst. The measurement results depicts the output RF spectrum in a graphic format, rather than numerical, as with the multiple-offset measurement. Limit lines corresponding with measurement limits as set by GSM specifications are displayed on the CRT. Pass or fail messages are displayed at the completion of the measurement.

NOTES

The default output RF spectrum measurements do not perform tests at frequency offsets greater than 1800 kHz from the carrier.

For each of the following measurements, enter all the information as specified in the “Configuring the test system for GSM Measurements” and “Entering Physical Channel Information” sections of this chapter. Especially enter the desired ARFCN and TN via the Physical Channel menu.

Measurement Procedures for Output RF Spectrum Due to Modulation

For Modulation in Multiple- and Single-Offset Mode

- 1 Press **Out RF Spectrum** in the Main menu.
- 2 Press **RF Spect Modulat**, then **MODULAT MULTIPLE**. Review the table that appears at the end of the measurement.
 - Press **NUMBER BURSTS** to change the number of bursts to be averaged, if desired. The preset value is 1 which allows the signal to be continually measured. For values greater than 1, the sweep stops after the selected number of bursts is reached. Changing the value automatically repeats the measurement.

NOTE:

A minimum of 25 sweeps are averaged for the 0 kHz offset, regardless of the “number of bursts” value.

- Press **Physical Channel**, press either **ARFCN** or **TIMESLOT NUMBER** and enter a new value if you want to change either of these settings. Press **Previous Menu** to return to the modulation multiple menu.

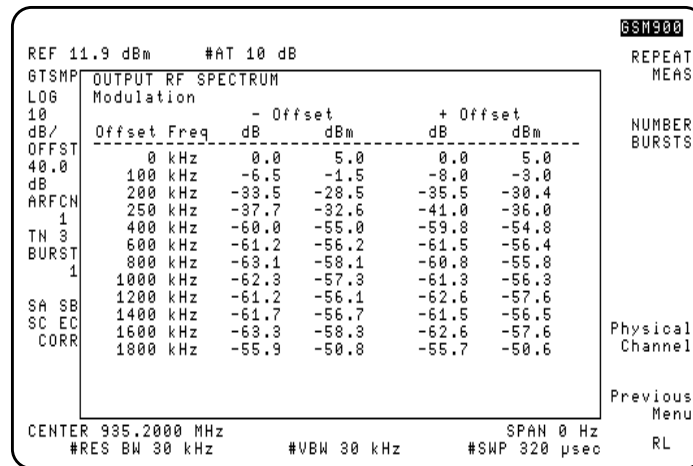

Figure 15 Example of Output RF Spectrum Due to Modulation - Multiple Offset Mode Measurement Result

- Press **Previous Menu**, then **MODULAT SINGLE** to examine the level at single offset frequencies.

Making GSM Measurements

Output RF Spectrum Measurements

- If in single-offset mode, press **CARRIER OFFSET** and enter the desired offset value. Use the step keys to change the value by 200 kHz increments.
- Press **REPEAT MEAS** to restart the measurement after making any settings changes or just to make the measurement again. You can also change parameters such as the resolution bandwidth, then repeat the measurement at the new resolution bandwidth setting by pressing **REPEAT MEAS**. Return to the current GSM menu from the spectrum analyzer keys by pressing **(MODE)**, **(MODE)**.

For Modulation in Swept Frequency Mode

- 1 Press **Out RF Spectrum** in the Main menu.
- 2 Press **RF Spect Modulat**, then **MODULAT SWEPT**. The measurement results are displayed at the completion of the test.
 - Press **NUMBER BURSTS** to change the number of bursts to be averaged, if desired. The preset value is 1 which allows the power versus time signal to be continually measured. For values greater than 1, the sweep stops after the selected number of bursts is reached. Changing the value automatically repeats the measurement.

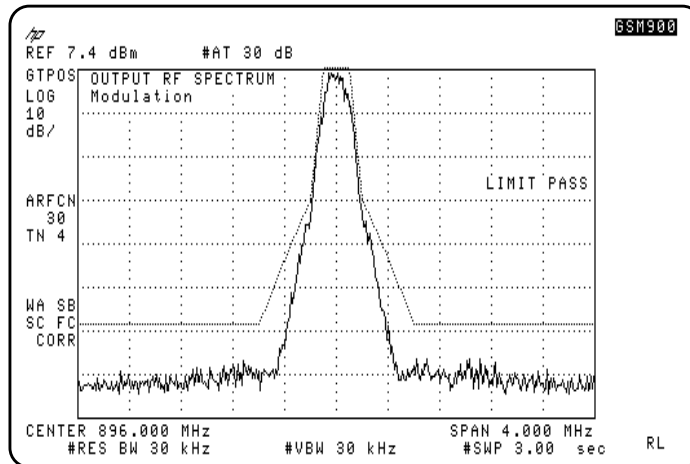

Figure 16 Example of Output RF Spectrum Due to Modulation - Swept Frequency Mode Measurement Result

- Press **Physical Channel**, then press either **ARFCN** or **TIMESLOT NUMBER** and enter a new value if you want to change either of these settings. Press **Previous Menu** to return to the carrier power menu.
- Press **SPAN** and enter a new value to change the frequency span.
- Press **REPEAT MEAS** to restart the measurement after making any settings changes or just to make the measurement again. You can also change parameters such as the resolution bandwidth, then repeat the measurement at the new resolution bandwidth setting by pressing **REPEAT MEAS**. Return to the current GSM menu from the spectrum analyzer keys by pressing **(MODE)**, **(MODE)**.

Measurement Procedures for RF Spectrum due to Switching Transients

For Transients in Multiple- and Single-Offset Mode

- 1 Press **Out RF Spectrum** in the Main menu.
- 2 Press **RF Spect Transnt**, then **TRANSNT MULTIPLE**. Review the results that appears at the completion of the measurement.

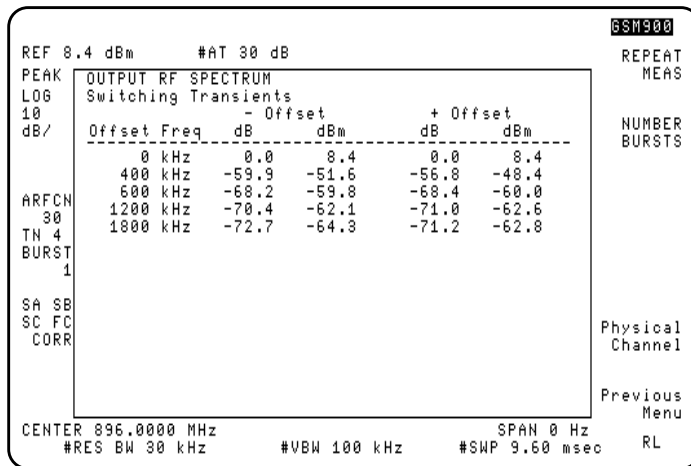

Figure 17 Example of Output RF Spectrum Due to Switching Transients - Multiple Offset Mode Measurement Result

- Press **NUMBER BURSTS** to change the number of bursts to be used, if desired. The preset value is 1 which allows the power versus time signal to be continually measured. For values greater than 1, the sweep stops after the selected number of bursts is reached. Changing the value automatically repeats the measurement.
- Press **Physical Channel**, then press either **ARFCN** or **TIMESLOT NUMBER** and enter a new value if you want to change either of these settings. Press **Previous Menu** to return to the transient multiple menu.
- Press **Previous Menu**, then **TRANSNT SINGLE** to examine the level at single offset frequencies.
- Press **CARRIER OFFSET**, if in single-offset mode, and enter the desired offset value. Use the step keys to change the value in 200 kHz increments.

- Press **REPEAT MEAS** to restart the measurement after making any settings changes or just to make the measurement again. You can also change parameters such as the resolution bandwidth, then repeat the measurement at the new resolution bandwidth setting by pressing **REPEAT MEAS**. Return to the current GSM menu from the spectrum analyzer keys by pressing **MODE**, **MODE**.

For Transient in Swept Frequency Mode

- 1 Press **Out RF Spectrum** in the Main menu.
- 2 Press **RF Spect Modulat**, then **TRANSNT SWEPT**. The results are displayed at the completion of the measurement.
 - Press **NUMBER BURSTS** to change the number of bursts to be used, if desired. The preset value is 1 which allows the power versus time signal to be continually measured. For values greater than 1, the sweep stops after the selected number of bursts is reached. Changing the value automatically repeats the measurement.

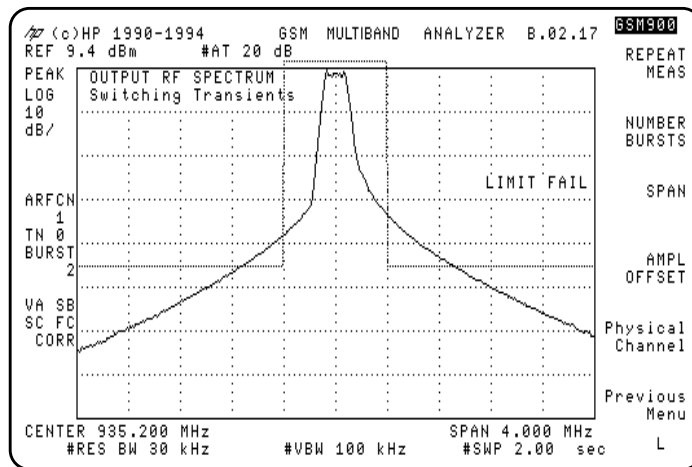

Figure 18 Example of Output RF Spectrum Due to Switching Transients - Swept Frequency Mode Measurement Result

- Press **Physical Channel**, then press either **ARFCN** or **TIMESLOT NUMBER** and enter a new value if you want to change either of these settings. Press **Previous Menu** to return to the carrier power menu.

Output RF Spectrum Measurements

- Press **SPAN** and enter a new value to change the frequency span.
- Press **REPEAT MEAS** to restart the measurement after making any settings changes or just to make the measurement again. You can also change parameters such as the resolution bandwidth, then repeat the measurement at the new resolution bandwidth setting by pressing **REPEAT MEAS**. Return to the current GSM menu from the spectrum analyzer keys by pressing **(MODE)**, **(MODE)**.

Measurement Procedures for Output RF Spectrum due to Modulation RX Band

- 1 Press **Out RF Spectrum** in the Main menu.
- 2 Press **RF Spect Modulat**, then **MODULAT RX BAND**. A caution and instruction message appears on the display.

CAUTION:

The spectrum analyzer is vulnerable to damage at the input during this measurement. The damage can occur because the input attenuator is set to 0 dB, and because the external attenuator is replaced by a bandpass filter. To *avoid analyzer damage*, you must observe the following precautions:

A receive-band bandpass filter (BPF) must be connected between the transmitter output and the spectrum analyzer INPUT 50Ω connector.

Make sure that the BPF used rejects the complete transmit band of the transmitter under test.

The total carrier power applied to the spectrum analyzer INPUT 50Ω *can not exceed +30 dBm*. If the input exceeds +30 dBm, spectrum analyzer damage may result.

- 3 Connect the receive-band BPF and the optional amplifier as illustrated in Figure 19 on page 63.

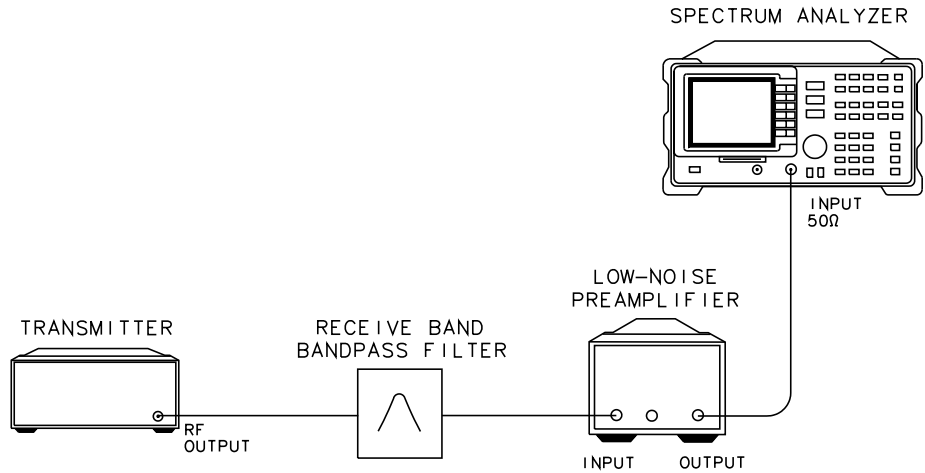

Figure 19 Test Setup for Transmitter Output RF Spectrum Due to Modulation - RX Band

- 4 Press **PREAMP GAIN** and enter the combined value of preamplifier gain, bandpass filter loss, and cable loss. For valid measurements, the total power at the spectrum analyzer INPUT 50Ω, needs to remain less than -10 dBm.
- 5 Press **CONTINUE** after the above steps are completed to activate the measurement.
- 6 Review the graphic display of measurement results that appear at the completion of the test.

Making GSM Measurements

Output RF Spectrum Measurements

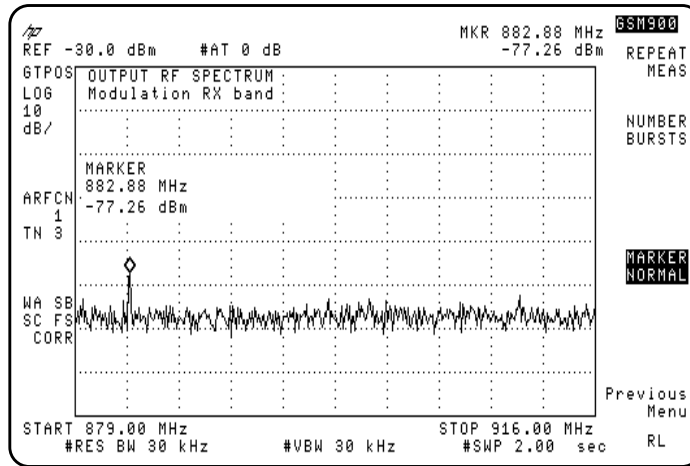

Figure 20 Example of Output RF Spectrum Due to Modulation - RX Band Measurement Result

- 7 Press **MS CLASS 1 2-5** to underline either mobile station class 1, or class 2 through 5. The setting of this key affects the position of the displayed limit line.

NOTE:

The **MS CLASS 1 2-5** key appears only if MS is underlined in **TX BS MS**.

- 8 Press **REPEAT MEAS** to repeat the measurement after you have changed any parameters or just to make the measurement again.
- 9 Press **NUMBER BURSTS** to change the number of bursts to be used, if desired. The default setting is 1 which allows the Output RF Spectrum in the RX band to be continually measured. For values greater than 1, the sweep stops after the selected number of bursts is reached. Changing the value automatically repeats the measurement.

Spurious Emissions Measurements

Description

The spurious emissions test measures the power level of emissions at frequencies other than those of the carrier and sidebands associated with normal modulation and switching transients.

An external frame trigger signal is *not* required for this measurement.

SFH mode is available for Transmitter Spurious - RX Band, Transmitter Spurious - Outside TX and RX Band, and Receiver Spurious - Outside TX Band measurements.

NOTE:

This test measures spurious emissions at the antenna connector. Radiated and power-lead conducted spurious emissions are not specifically measured by the HP 85727A GSM Multiband Transmitter Measurement Personality.

There are two groups of spurious emissions tests. One group measures transmitter spurious emissions, and the other group measures receiver spurious emissions. These two measurement groups each provide different test modes which are listed in their measurement descriptions.

At the completion of any test, a table of emissions that exceed or are within 6 dB of the GSM specifications are listed by frequency and amplitude pairs.

NOTE:

Standard measurement limits for GSM900 are used for this measurement. If you are making measurements in the R-GSM ARFCN range (955-974) and need to use the specified limits refer to the section “To modify the default values or limit line functions used by the personality” in the *HP 85727A GSM Multiband Transmitter Measurement Personality Remote Programming Guide*.

NOTE:

Spurs in the table that are asterisked (*), indicate that they may actually be spectrum analyzer noise. In these cases, the spectrum analyzer's sensitivity specification exceeds or is within 6 dB of the GSM spurious emissions specification. Investigate the spur more closely by removing the input signal. If the suspect spur remains, it is spectrum analyzer noise.

Measuring Transmitter Spurious Emissions

- 1 Press **More 1 of 2**, then **Spurious Emission** in the Main menu.
- 2 Press **Xmtr Spurious**.
- 3 Press **TX BAND**. Refer to Figure 21 for the test setup. The spectrum analyzer scans the band indicated and lists in a table the spurious signals that are found.

NOTE:

The transmitter must *not* be in SFH mode during this measurement.

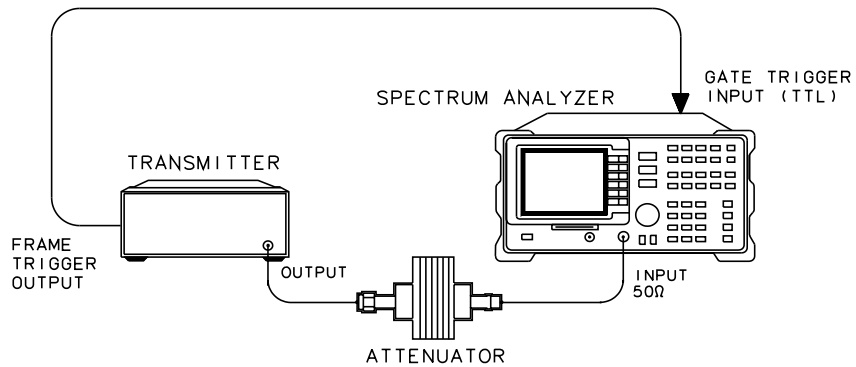

Figure 21 Test Setup Transmitter Spurious Emissions - TX Band/Outside Band

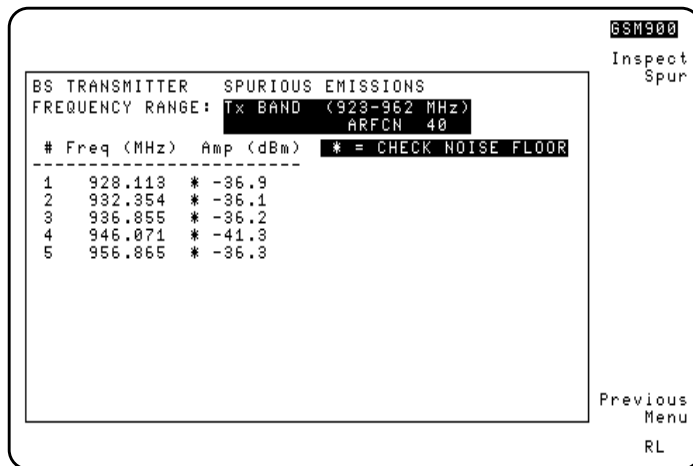

Figure 22 Example of Spurious Emissions in TX Band Measurement Result

- 4 Press **INSPECT SPUR** at the completion of a measurement to examine a spur in the table more closely.
 - a Press **ENTER SPUR #**.
 - b Use the data keys to enter the number of the spur you want to review, then terminate the number with the **(ENTER)** key, or press **(▲)** or **(▼)** to automatically display other spurs. The spectrum analyzer state is automatically set to the state it was in when the spur was detected.

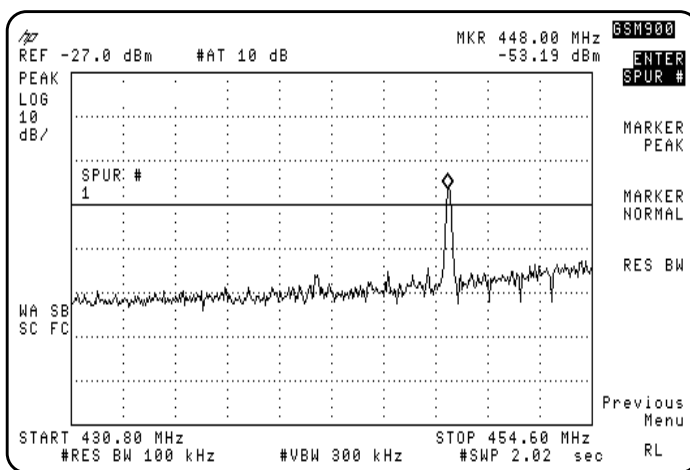

Figure 23 Example of Inspecting Spurs Routine

Making GSM Measurements

Spurious Emissions Measurements

- c Press **Previous Menu** to return to the table of spurs found.
 - d Press **Previous Menu** again to return to the **Xmtr Spurious** key.
 - 5 Press **OUTSIDE TX RX**. Refer to Figure 24 on page 69 for the test setup. During the measurement, the spectrum analyzer scans outside the GSM transmit and receive bands for spurious signals. Spurious signals found are listed in a table.
 - 6 Press **INSPECT SPUR** at the completion of a measurement to examine a spur in the table more closely, if any spurs were found.
 - a Press **INSPECT SPUR #**.
 - b Use the data keys to enter the number of the spur you want to review, then terminate the number with the **(ENTER)** key, or press **(▲)** or **(▼)** to automatically display other spurs. The spectrum analyzer state is automatically set to the state it was in when the spur was detected.
 - c Press **Previous Menu** to return to the table of spurs found.
 - d Press **Previous Menu** again to return to the **Xmtr Spurious** key.

NOTES

For spurs which are harmonically related to the carrier signal, and less than 2.9 GHz, spectrum analyzer distortion may mask the actual spurious amplitude level. To determine if this is the case, increase the spectrum analyzer input attenuator settings. Any change in the measured value of the signal indicates the spur is due to spectrum analyzer distortion.

The **SPUR TST ON OFF** softkey can be used in the majority of applications to detect spurs which are internally generated by the spectrum analyzer without affecting the measurement of the external spurs. If the spur is determined to be internally generated it is removed from the table of spurious signals.

-
- 7 Press **RX BAND**. For RX band spurious emissions measurements, a caution and instruction message appears on the display. Connect the receive-band BPF and the preamplifier as illustrated in Figure 24 on page 69.

CAUTION:

In this test setup, the transmitter output power is reflected by the bandpass filter back into the transmitter output port. Before connecting the equipment, make sure the transmitter can handle this power reflection without causing damage.

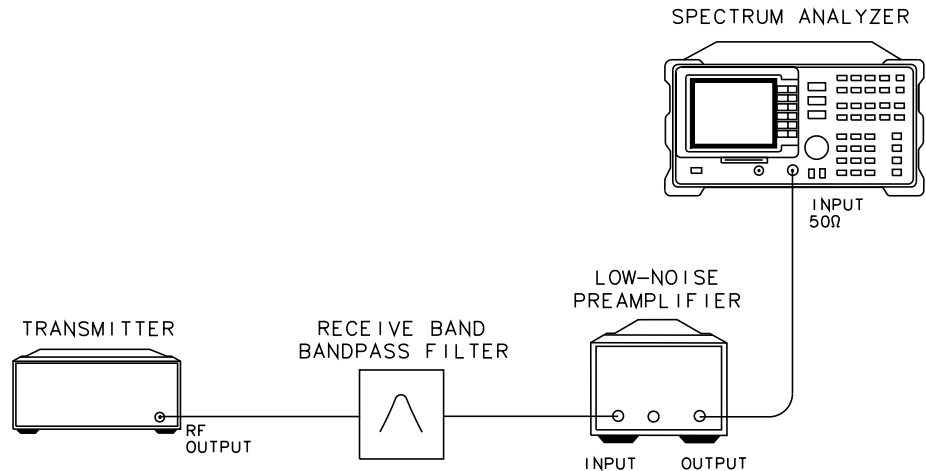

Figure 24 Test Setup for Spurious Emissions - RX Band

CAUTION:

The spectrum analyzer is vulnerable to damage at the input during the RX Band spurious emissions measurement. The damage can occur because the input attenuator is set to 0 dB, and because the external attenuator is replaced by a bandpass filter. To *avoid analyzer damage*, you must observe the following precautions:

A receive-band bandpass filter (BPF) must be connected between the transmitter output and the spectrum analyzer INPUT 50Ω connector.

Make sure that the BPF used rejects the complete transmit band of the transmitter under test.

The total carrier power applied to the spectrum analyzer INPUT 50Ω *can not exceed +30 dBm*. If the input exceeds +30 dBm, spectrum analyzer damage may result.

- Set the preamplifier gain correction factor to a value that takes into account the gain of the preamplifier, insertion loss of the bandpass filter, and any cable loss. For valid measurements, the total input power at the INPUT 50Ω connector must be kept to less than -10 dBm.

8 Press **CONTINUE** after the above steps are completed to start the measurement.

Making GSM Measurements

Spurious Emissions Measurements

- 9 Press **INSPECT SPUR** at the completion of a measurement to examine a spur in the table more closely, if any spurs were found.
 - a Press **ENTER SPUR #**.
 - b Use the data keys to enter the number of the spur you want to review, then terminate the number with the **(ENTER)** key, or press **(▲)** or **(▼)** to automatically display other spurs. The spectrum analyzer state is automatically set to the state it was in when the spur was detected.
 - c Press **Previous Menu** to return to the table of spurs found.
 - d Press **Previous Menu** again to return to the **Xmtr Spurious** key.

Measuring Mobile Station Transmitter (in Idle Mode) Spurious Emissions

To test mobile stations in idle mode, underline YES in **IDLE YES NO**. *Specification GSM 11.10* specifies the measurement of TX Band and Outside TX Band spurious emissions. Refer to Figure 25 on page 70 below for the test setup. Conduct the measurement as instructed in the previous section.

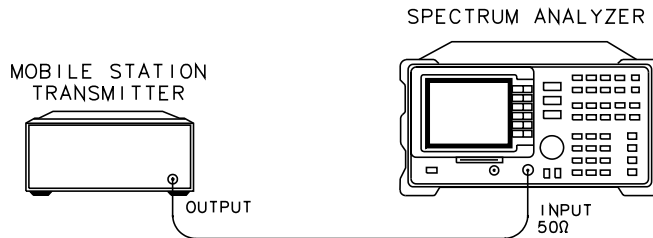

Figure 25 Test Setup for Spurious Emissions - Mobile Station Transmitter in Idle Mode

Measuring Receiver Spurious Emissions

- 1 Press **More 1 of 2**, then **Spurious Emission** in the Main menu.
- 2 Press **Rcvr Spurious**. Refer to Figure 26 on page 71 for the test setup.

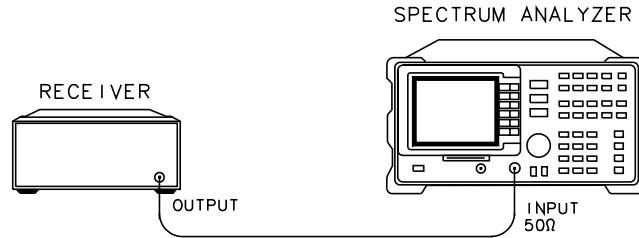

Figure 26 Test Setup for Receiver Spurious Emissions

- 3 Press **TX BAND**, the spectrum analyzer uses the current value of ARFCN and scans the band indicated and lists valid spurious signals in a table.

NOTE:

The transmitter must not be in SFH mode during this measurement.

- 4 Press **INSPECT SPUR** at the completion of the measurements to examine a spur in the table.
 - a Press **ENTER SPUR #** and enter the number of the spur you want to review. The spectrum analyzer state is automatically set to the state it was in when the spur was detected.
 - b Press **Previous Menu** to return to the table of spurs found.
 - c Press **Previous Menu** again to return to the **Rcvr Spurious** key.
- 5 Press **OUTSIDE TX BAND**. The spectrum analyzer scans the bands outside the GSM transceiver transmit band for spurious signals. Spurious signals that are found are listed in a table.
 - a Press **ENTER SPUR #** and enter the number of the spur you want to review. The spectrum analyzer state is automatically set to the state it was in when the spur was detected.
 - b Press **Previous Menu** to return to the table of spurs found.
 - c Press **Previous Menu** again to return to the **Rcvr Spurious** key.

NOTE:

The **SPUR TST ON OFF** softkey can be used in the majority of applications to detect spurs which are internally generated by the spectrum analyzer without affecting the measurement of the external spurs. If the spur is determined to be internally generated it is removed from the table of spurious signals.

Intermodulation Attenuation Measurements

Description

The intermodulation attenuation measurement checks the capability of the base-station transmitter to inhibit the generation of intermodulation distortion products. Intermodulation products are caused by the interaction of the carrier and an interfering signal in the non-linear elements of the transmitter.

For the TX band measurement, the intermodulation attenuation value is defined as the dB ratio of the carrier output power to the highest intermodulation component. For this test, the transmitter is set to maximum power and SFH mode is disabled.

The two parts of the intermodulation attenuation measurement are as follows:

- The **TX BAND** selection tests for intermodulation products that fall within the base station transmitter's transmit band. For this test, a CW test signal is injected into the transmitter at either 800 kHz above or 800 kHz below the carrier signal.
- The **RX BAND** selection tests for the intermodulation products that fall within the receive band of the base station. For this test, a CW test signal is injected into the transmitter. The CW test signal is separated from the carrier, such that the third-order, fifth-order, or seventh-order intermodulation product falls on the corresponding channel in the receive band.

An external CW source is required to create the interfering signal. A circulator is also required. In testing the receive band (880 MHz to 915 MHz), a preamplifier and receive-band BPF is needed.

For both measurements, the carrier output power is first measured. The CW source is then set 30 dB below the carrier's power level to produce the selected intermodulation product.

An external frame trigger signal is *not* required for this measurement.

NOTE:

The intermodulation attenuation measurements only test for expected intermodulation products at selected frequencies.

For TX Band Intermodulation Products

- 1 From the Main menu, press **More 1 of 2**, then **Intermod**.
- 2 Press **Intermod Atten**, then **TX BAND**. Refer to Figure 27 for the initial test setup. If a carrier is present, the spectrum analyzer measures the carrier to determine its peak power.

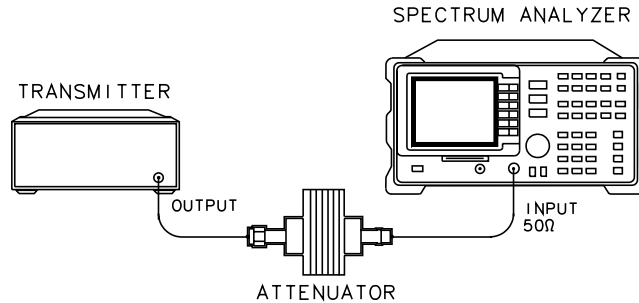

Figure 27 Test Setup for Initial Intermodulation Attenuation Measurement

NOTE:

Intermodulation attenuation measurements are relative to a carrier. If a carrier with a signal level greater than -10 dBm is not detected, the message **NO CARRIER, TEST STOPPED!** appears. Check the cable connections to the spectrum analyzer input.

- 3 Read the message that appears on the display.
- 4 Decide whether you want the interfering signal 800 kHz above or 800 kHz below the carrier. Refer to the steps below:
 - a Press **ABOVE** to measure intermodulation products due to an interfering signal 800 kHz above the carrier.
 - b Press **BELOW** to measure intermodulation products due to an interfering signal 800 kHz below the carrier.
- 5 Read the message that appears on the display and connect the equipment as described in the text. Refer to Figure 28 on page 74 for the equipment setup.

Making GSM Measurements
Intermodulation Attenuation Measurements

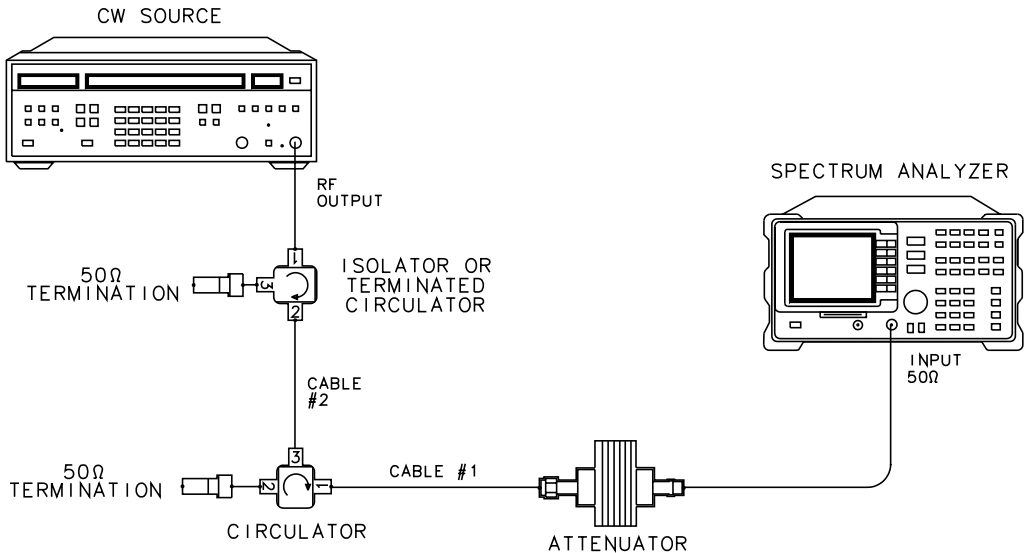

Figure 28 Test Setup for CW Source Adjustment

- 6 Press **CONTINUE** when you are ready.
- 7 Adjust the CW source frequency and amplitude for the values displayed in the upper left-hand corner of the graticule. The CW source frequency should be in the center of the display. The source amplitude should be at the display line on the display.
- 8 Press **CONTINUE** when ready.

NOTE:

If the CW source frequency or amplitude are not set correctly, the message **FREQUENCY >0.1 MHz OFF!** or **AMPLITUDE >1 dB OFF!** appears. The measurement can continue, however, the final measurement results may not be valid.

- 9 Read the text and make the test setup connections described in the displayed text. Refer to Figure 29 on page 75 for the test setup.

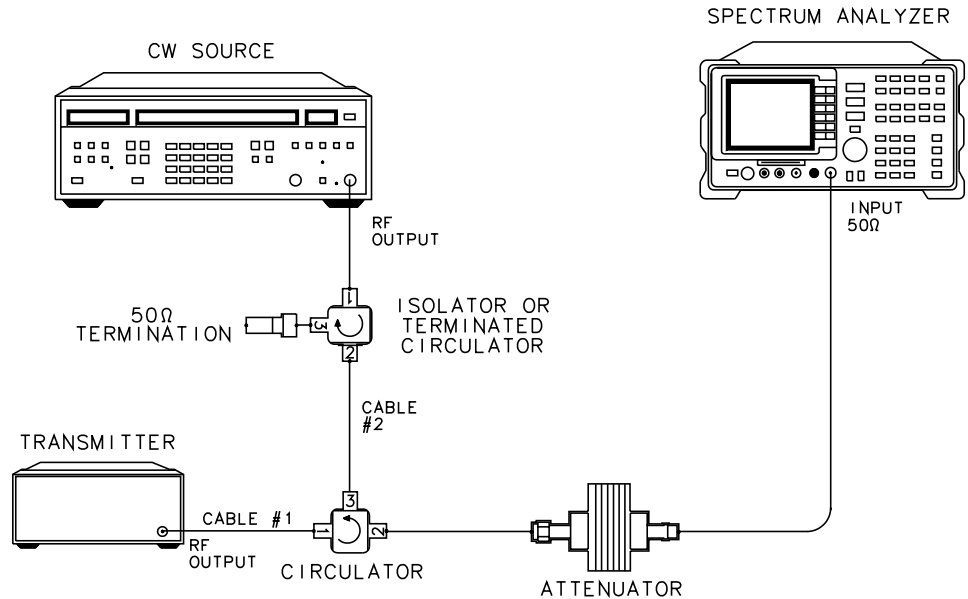

Figure 29 Test Setup for Intermodulation Attenuation - TX Band

10 Press **CONTINUE** when you are ready to start the measurement. The test results are displayed at the completion of the measurement.

NOTE:

If a carrier >-20 dBm is not detected, the message **NO CARRIER, CHECK SETUP!** appears. The setup information from the previous screen is displayed again.

The measurement result trace is stored in a viewed trace. A second trace is enabled to sweep. Adjustments that affect the level of the products may then be made. The results are immediately displayed on the sweeping trace.

Making GSM Measurements
Intermodulation Attenuation Measurements

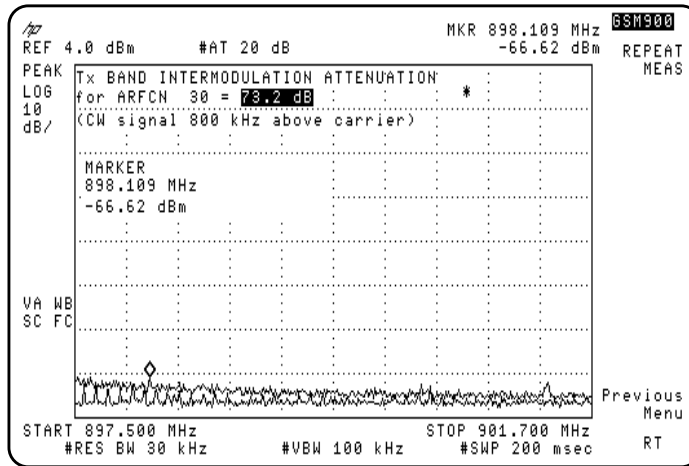

Figure 30 Example of Intermodulation Attenuation - TX Band Measurement Result

- 11 Press **REPEAT MEAS** to restart the measurement after making any settings changes or just to make the measurement again.
- 12 Press **Previous Menu** to return to the top level Intermod Atten menu. You can select another ARFCN or intermodulation product in the top level menu.

For RX Band Intermodulation Products

- 1 Connect the equipment as shown in Figure 31. Press **Intermod Atten**, then **RX BAND**. If a carrier is present, the spectrum analyzer measures the carrier to determine its peak power.

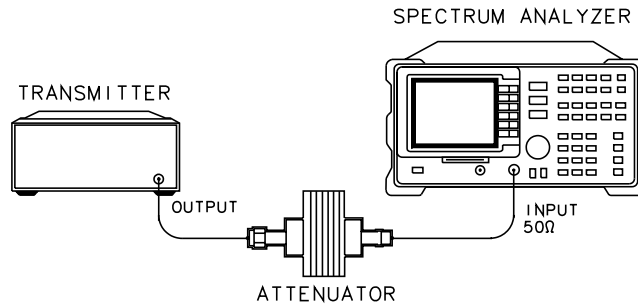

Figure 31 Test Setup for Initial Intermodulation Attenuation - RX Band

NOTE:

If a carrier is not detected, the message **NO CARRIER, TEST STOPPED!** appears. Check the connections to the spectrum analyzer input. Repeat the above steps after you have resolved the problem.

- 2 Read the message that appears on the display. Decide whether you want the interfering signal to produce third, fifth, or seventh order intermodulation products. Refer to the descriptions below:
 - Press **3rd** to measure an intermodulation product due to an interfering signal producing a 3rd order product.
 - Press **5th** to measure an intermodulation product due to an interfering signal producing a 5th order product.
 - Press **7th** to measure an intermodulation product due to an interfering signal producing a 7th order product.
- 3 Read the text displayed and make the connections described. Refer to Figure 32 on page 78 for the equipment setup.

Making GSM Measurements
Intermodulation Attenuation Measurements

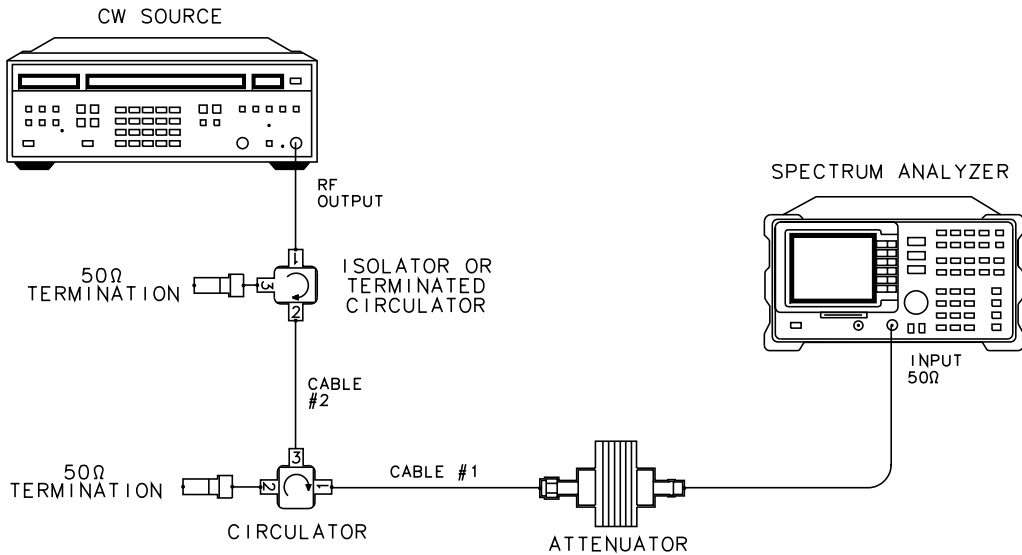

Figure 32 Test Setup for CW Source Adjustment

- 4 Adjust the CW source frequency and amplitude for the values displayed in the upper left-hand corner of the graticule. The CW source frequency should be in the center of the display. The source amplitude should be at the display line on the display.
- 5 Press **CONTINUE** when ready.

NOTE:

If the CW source frequency or amplitude are not set correctly, the message **FREQUENCY >0.1 MHz OFF!** or **AMPLITUDE >1 dB OFF!** appears. The measurement can continue, however, the final measurement results may not be valid.

- 6 Read the text and make the test setup connections described in the displayed text. Refer to Figure 33 on page 79 for the test setup.

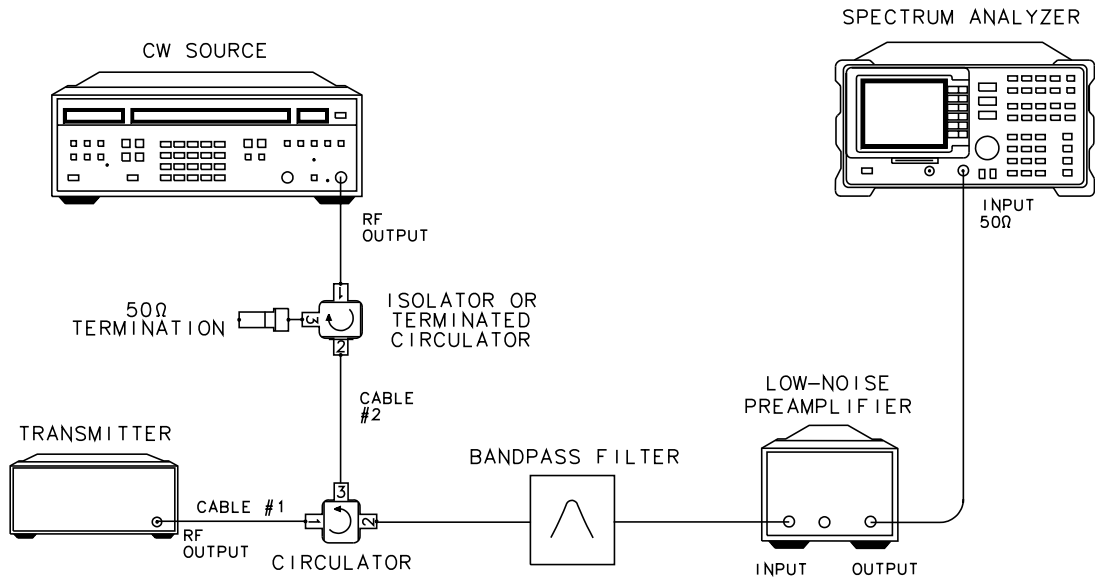

Figure 33 Test Setup for Intermodulation Attenuation - RX Band

CAUTION:

The spectrum analyzer is vulnerable to damage at the input during this measurement. The damage can occur because the input attenuator is set to 0 dB, and because the external attenuator is replaced by a bandpass filter. To *avoid analyzer damage*, you must observe the following precautions:

A receive-band bandpass filter (BPF) must be connected between the transmitter output and the spectrum analyzer INPUT 50Ω connector.

Make sure that the BPF used rejects the complete transmit band of the transmitter under test.

The total carrier power applied to the spectrum analyzer INPUT 50Ω *can not exceed +30 dBm*. If the input exceeds +30 dBm, spectrum analyzer damage may result.

For the test setup illustrated in Figure 33 on page 79, the base station output power is reflected from the bandpass filter (BPF), through the circulator, and into the isolator/circulator at the output of the CW source. Make certain that this isolator/circulator is capable (rated) of dissipating the output power generated by the base station transmitter. Failure to supply an adequately rated isolator/circulator can damage the isolator/circulator or the CW source.

Making GSM Measurements

Intermodulation Attenuation Measurements

7 Press **CONTINUE** when ready.

NOTE:

If a carrier larger than -20 dBm is detected, the message **CARRIER PRESENT, CHECK SETUP!** is displayed. The test setup screen is displayed again.

8 Read the caution screen that is displayed. Verify the test setup connections.

9 Adjust the **PREAMP GAIN** value displayed, if necessary. This value needs to be the combined preamplifier gain, cable loss, BPF loss values in the next screen. Press **CONTINUE** to activate the measurement. The test results are displayed at the completion of the measurement. The measurement results trace is stored in a viewed trace, and a second trace is enabled to sweep. Adjustments that affect the level of the products may then be made, and the results are immediately viewed on the sweeping trace.

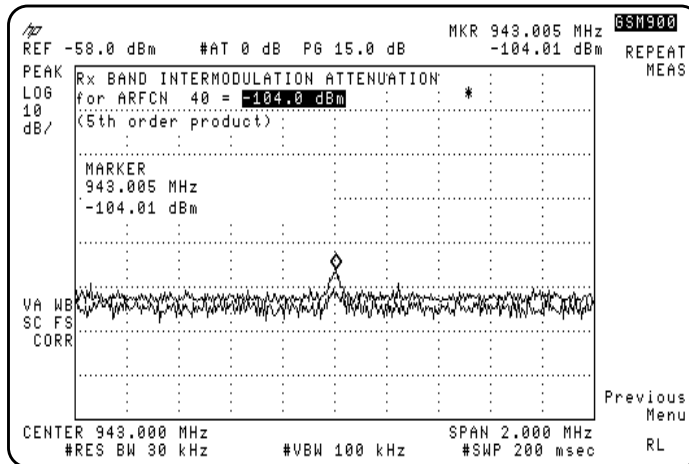

Figure 34 Example of Intermodulation Attenuation - RX Band Measurement Results

10 Press **REPEAT MEAS** to restart the measurement after making any settings changes or just to make the measurement again.

11 Press **Previous Menu** to return to the top level Intermod Atten menu. You can select another intermodulation product in the top level menu.

Intra-BSS Intermodulation Attenuation Measurements

Description

The intra-base station measurement examines the intermodulation products caused by combining several transmitters to a single antenna. The leakage of each carrier into the other transmitters and the presence of non-linear elements causes intermodulation products to appear.

This test assumes that in addition to the other carriers, there is a reference channel (ARFCN=3) present. You can change the ARFCN to another channel, if desired. Press **REF CHANNEL**, then enter the number of the desired channel. The transmitters are set to maximum power and the channel spacing is set to minimum.

For the TX Band measurement, the Intra-BSS Intermodulation Attenuation measurement is defined as the dB ratio of the reference channel carrier output power to the highest intermodulation component.

The Intra-BSS measurement is divided into the following two parts:

- The **TX BAND** selection measures intermodulation products that occur within the transmitters transmit band.
- The **RX BAND** selection measures intermodulation products which fall within the transmitters receive-band. The receive-band measurement requires the use of an external preamplifier and receive-band bandpass filter (BPF).

An external frame trigger signal is *not* required for this measurement.

NOTES

The default intra-BSS intermodulation attenuation measurements do not perform tests at frequency offsets greater than 1800 kHz from the carrier.

In certain cases, spectrum analyzer distortion products may mask intermodulation products. To determine the cause of the product, increase the spectrum analyzer's input attenuator setting. Any change in the indicated value of the signal indicates the product is due to spectrum analyzer distortion products.

For TX Band Intra-BSS Intermodulation

CAUTION:

The total power of all carriers may exceed the rated value of the recommended 30 dB attenuator (HP 8498A Option 030 attenuator) or the +30 dBm safe input level to the of the spectrum analyzer's INPUT 50Ω connector. Be sure to provide adequate protection if this is a potential during your measurement to prevent damage to the attenuator or the spectrum analyzer.

- 1 Refer to Figure 35 on page 82 for the test setup.

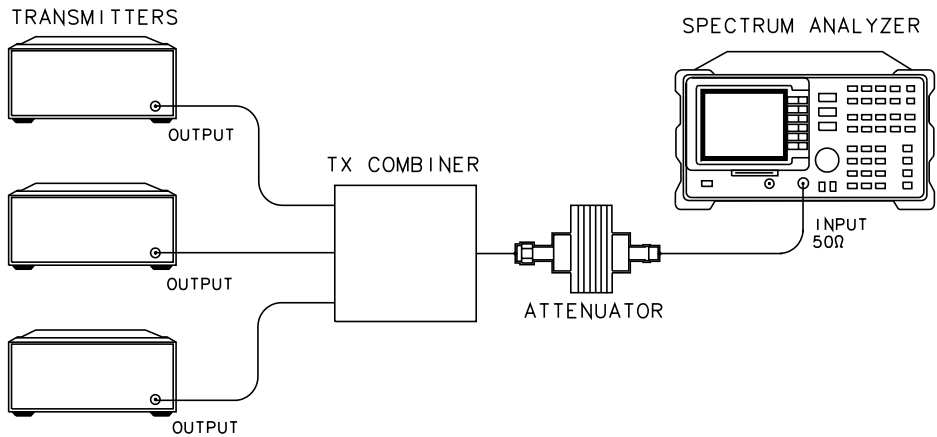

Figure 35 Test Setup for Intra-BSS Intermodulation - TX Band

- 2 Press **Intermod**, then **IntraBss Intermod** and **TX BAND**. If carriers are detected, the spectrum analyzer measures the total power to determine the analyzer reference level setting, then measures the reference channel output power. Once these measurements are finished, the Intra-BSS Intermodulation measurement starts.

NOTE:

If a carrier is not detected, the message **NO CARRIER, TEST STOPPED!** is displayed. This test requires a carrier signal because it is a dB relative measurement.

If the reference channel is not detected, the message **REFERENCE CHANNEL NOT PRESENT! TEST STOPPED!** is displayed.

- 3 At the completion of the measurement, the results are displayed in the upper left-hand corner of the display. The results trace is stored in a viewed trace, and a second trace is enabled to sweep. Adjustments that affect the level of the products may then be made, and the results are immediately viewed on the sweeping trace.
-

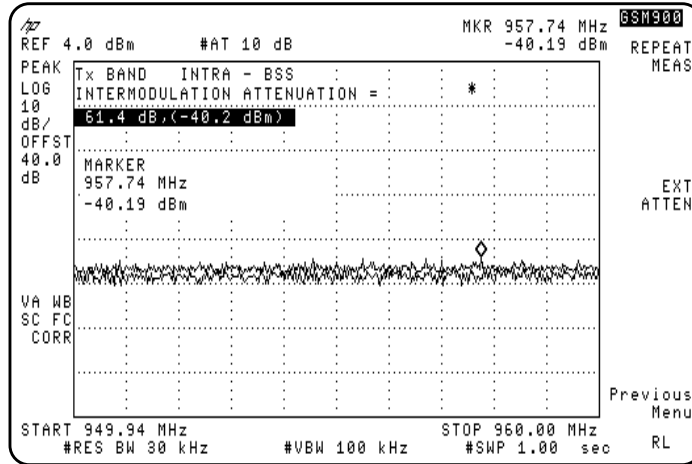

Figure 36 Example of Intra-BSS - TX Band Measurement Result

- 4 Press **REPEAT MEAS** to restart the measurement after making any settings changes or just to make the measurement again.
- 5 Press **Previous Menu** to return to the top level Intra-BSS Intermodulation menu.

NOTE:

If the spectrum analyzer's sensitivity specification is greater than the GSM intermodulation attenuation specification, the message **CHECK NOISE FLOOR!** appears.

For RX Band Intra-BSS Intermodulation

For sufficient dynamic range, a preamplifier and bandpass filter (with a frequency range covering the receive-band frequencies), must be included in the test setup. Refer to the text on the display.

CAUTION:

The spectrum analyzer is vulnerable to damage at the input during this measurement. The damage can occur because the input attenuator is set to 0 dB, and because the external attenuator is replaced by a bandpass filter. To *avoid analyzer damage*, you must observe the following precautions:

A receive-band bandpass filter (BPF) must be connected between the transmitter output and the spectrum analyzer INPUT 50Ω connector.

Make sure that the BPF used rejects the complete transmit band of the transmitters under test.

The total carrier power applied to the spectrum analyzer INPUT 50Ω *can not exceed +30 dBm*. If the input exceeds +30 dBm, spectrum analyzer damage may result.

- 1 Refer to Figure 37 on page 84 for the test setup.

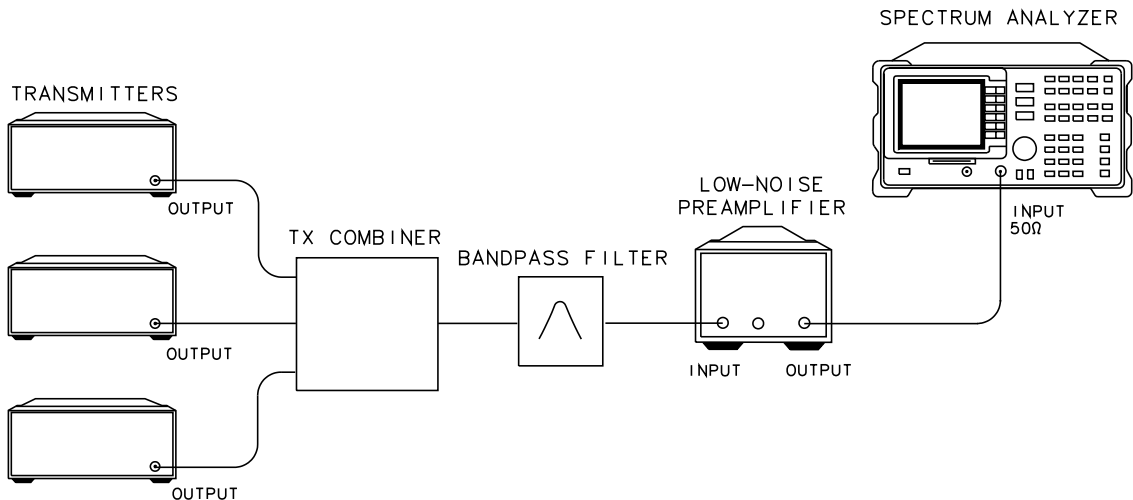

Figure 37 Test Setup for Intra-BSS Intermodulation - RX Band

- 2 Press **Intermod**, **IntraBss Intermod**, then **RX BAND**.

- 3 Read the caution screen displayed. Read the text, then verify the connections.
- 4 Adjust the displayed **PREAMP GAIN** value if necessary. This value needs to be the combined value of preamplifier gain, cable loss, and BPF loss. Press **CONTINUE** to activate the measurement.

NOTE:

If a carrier >-20 dBm is detected, the message **CARRIER PRESENT, TEST STOPPED!** is displayed.

- 5 The measurement results are displayed on the screen at the completion of the test. The results trace is stored in a viewed trace, and a second trace is enabled to sweep. Adjustments that affect the level of the products may then be made, and the results are immediately viewed on the sweeping trace.
- 6 Press **REPEAT MEAS** to restart the measurement after making any settings changes or to make the measurement again.
- 7 Press **Previous Menu** to return to the top level Intra-BSS Intermodulation menu.

Phase and Frequency Error Measurements

Description

The phase and frequency error measurement analyzes the accuracy of the transmitters GMSK modulation. The phase and frequency errors on the useful part of the burst are calculated by obtaining a sample of the transmitted phase trajectory and comparing it with the theoretically expected phase trajectory. This measurement allows you to display these errors numerically and graphically on the spectrum analyzer display. It also allows you to view a binary representation of the demodulated data bits.

NOTE:

It is essential that an external trigger signal is applied for this measurement, otherwise the spectrum analyzer does not complete the measurement. Once the external trigger signal is applied the spectrum analyzer will continue to function correctly.

Although single burst measurements can be made, the measurement process requires that multiple triggers are received. In normal circumstances, with a repetitive frame trigger, this need is satisfied.

Test Procedure

- 1 Enter all the information as specified in the “Configuring the test system for GSM Measurements” and “Entering Physical Channel Information” sections of this chapter.
- 2 Press **More 1 of 2, Phase & Freq Err** in the Main menu.
- 3 Refer to Figure 38 on page 86 for the test setup.

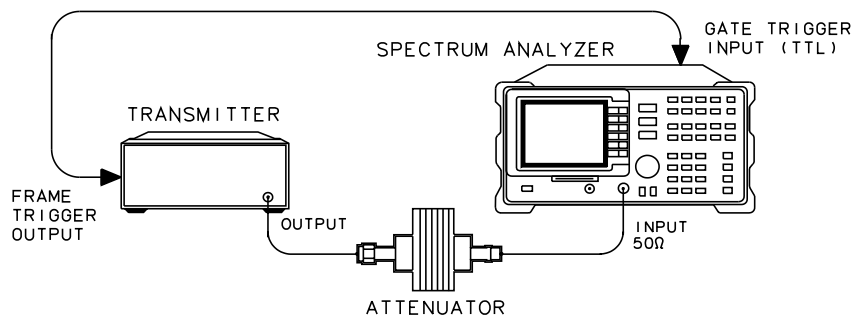

Figure 38 Test Setup for Phase and Frequency Error

- 4 Press **PHASE FREQ** to make the phase and frequency error measurement.

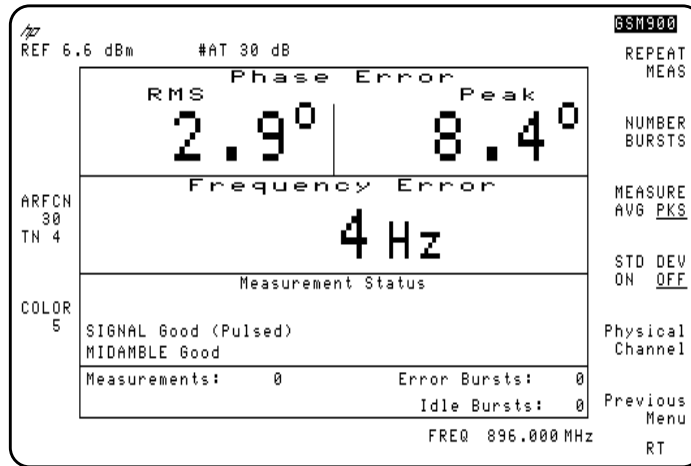

Figure 39 Example of Phase and Frequency Error Measurement Result

- 5 Press the **Meas Config** key to access a menu which allows you to modify the phase and frequency error test parameters.
- Press **Burst Type** to select the type of burst expected for the measurement.
 - Press **COLOR AUTO MAN** to select either automatic or manual detection of the color pattern sent by the transmitter.
 - Press **SYNC MID AMPL** to select which signal the spectrum analyzer uses for synchronization. Underline MID to select synchronization using the midamble section of the burst. Underline AMPL to select synchronization using the rising edge of the burst.
 - Press **MEASURE AVG PKS** and underline AVG to activate the averaging measurement. Underline PKS to activate the minimum-peaks and maximum-peaks measurement. This selection only applies when **NUMBER BURSTS** is greater than 1. The main displayed result is the average, or peak value from the selected number of bursts.
 - Press **FREQ ERR OFFSET** to enter a known frequency error within your system. This error is then subtracted from all the measured values, giving more accurate measurement results.
 - Press **Previous Menu** to return to the measurement menu.

- 6 To further modify the phase and frequency error test parameters the following keys can be pressed.
 - Press **NUMBER BURSTS** to change the number of bursts to be measured, if desired. The preset value is 1 phase and frequency error signal to be continually measured. For values greater than 1, the sweep stops after the selected number of bursts is reached. Changing the value automatically repeats the measurement.
 - Press **Physical Channel**, then press either **ARFCN** or **TIMESLOT NUMBER** and enter a new value if you want to change either of these settings.
- 7 Press **REPEAT MEAS** to restart the measurement after making any settings changes or just to make the measurement again. If you have gone to the spectrum analyzer menu you can return to the current GSM menu by pressing **(MODE)**, **(MODE)**.
- 8 If you wish to view a graph of the errors press **Graphs** in the Phase and Frequency Error Measurement Menu. This accesses a menu which allows you to select the graph which you wish to display; either the phase, frequency deviation or phase and frequency graph. The graph displays also show the numerical values of the peak phase error, the RMS phase error, the frequency error and the sync status.
- 9 If you wish to view a binary representation of the demodulated signal press **DATA BITS** in the Phase and Frequency Error Measurement Menu. Midamble bits are indicated with an "M".

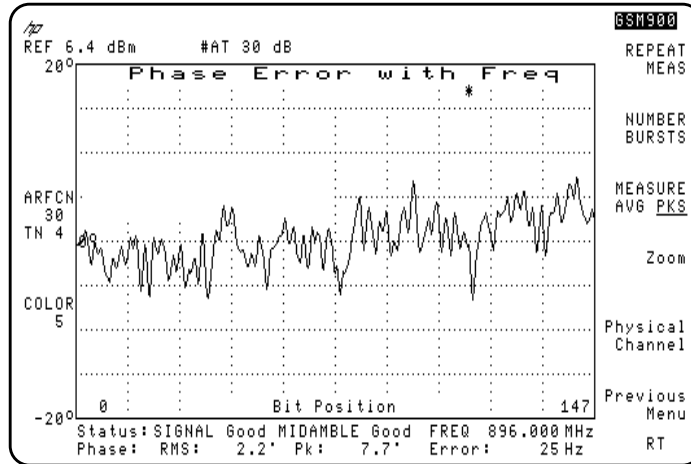

Figure 40 Example of Phase and Frequency Error Measurement - Phase Error with Frequency Graph

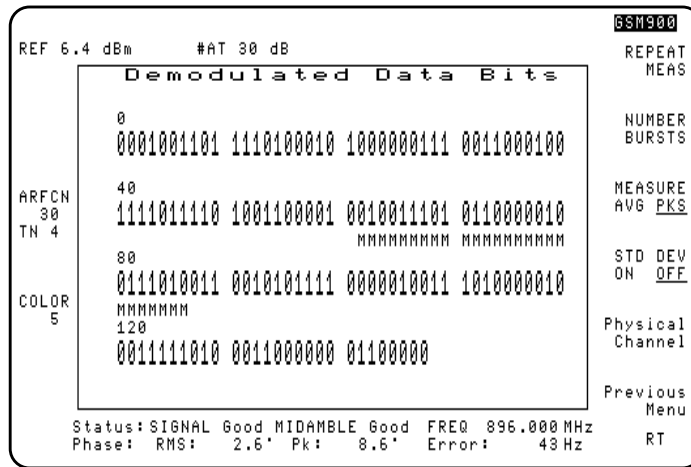

Figure 41 Example of Phase and Frequency Error Measurement - Demodulated Data Bits

Monitor TX Band Measurements

Description

The monitor transmit band measurement displays the frequency spectrum of the full transmit band for either the mobile station or base station, as selected with the **TX MS BS** key.

During the measurement, the following conditions are set:

- The spectrum analyzer's input attenuator is automatically set to an optimum level that is based upon the total measured power of all carriers present.
- The reference level is automatically set so that the maximum carrier is positioned 5 dB below the top graticule line.

The total transmit band power is displayed and continually updated at the end of each sweep. When this measurement is made, the first calculated total power value is used to update the **TOTL PWR SGL MULT** setting.

The **TOTL PWR SGL MULT** key selection only applies to the channel measurements such as Carrier Power, Power vs. Time, and Output RF Spectrum measurements.

- If **MULT** is underlined in the **TOTL PWR SGL MULT** key, the input attenuator is automatically set to the optimum value based upon the total power measured during the Monitor TX Band measurement.
- If **SGL** is underlined in the **TOTL PWR SGL MULT** key, the input attenuator is automatically set to the optimum value based upon the currently measured carrier power at the selected ARFCN.

To ensure correct total power calculations, all of the carriers must be at least (1 MHz) apart. An external frame trigger is *not* required for this measurement.

Test Procedure

- 1 Enter the configuration information as specified in the “Configuring the test system for GSM Measurements” section of this chapter.
- 2 Press **More 1 of 2**, then **MONITOR TX BAND** in the Main menu. The spectrum at the selected TX band is displayed. The total TX band peak power is

calculated and the displayed value updated at the end of every sweep.

Making GSM Measurements
Monitor TX Band Measurements

**Making Measurements in
Spectrum Analyzer Mode**

Making Spectrum Analyzer Measurements

What You'll Learn in This Chapter

This chapter demonstrates spectrum analyzer measurement techniques you may find useful in addition to the measurements provided by the GSM Multiband Transmitter Measurement Personality. Use the menus available from the spectrum analyzer **(MODE)** key to switch between spectrum analyzer mode and GSM analyzer mode at any time.

It contains the following sections:

- Limit Line Functions.
- Amplitude Correction Factors.
- Windows Display.
- Gate Utility.
- Time Gating.

Limit-Line Functions

Limit lines provide an easy way to compare trace data to a set of amplitude and frequency parameters while the spectrum analyzer is sweeping the measurement range. An upper and/or lower limit line can be displayed. Every measurement sweep of trace A is compared to the limit lines. If trace A is at or within the bounds of the limit lines, **LIMIT PASS** is displayed. If trace A is out of the limit-line boundaries, **LIMIT FAIL** is displayed. Figure 42 on page 96 shows a sample limit-line display.

Limit lines are constructed from a table of frequency and amplitude coordinate pairs. Limit line segments are created by connecting these points. Everything except the segment length is defined by the entry for its beginning point. There are several different ways of entering the frequency/amplitude pairs. These are described in the following section.

NOTE:

Limit lines can only be created and edited from the front panel in the format of limit line tables. Limit lines that are in a trace format can only be created using remote commands or a down-loadable program. See *HP 8590E-Series Spectrum Analyzer Programmer's Guide* for more information.

Though coordinates of frequency and amplitude are used most often, limit line data can also be entered in terms of time and amplitude. Use the **LIMITS FRQ TIME** softkey, to underline the desired choice of either frequency or time parameters. Frequency is the default selection. If **TIME** is selected **SELECT TIME** will replace **SELECT FREQ** in the Edit Limit menus.

This section provides an overview of limit lines, a procedure for creating a sample upper limit line, and descriptions of the limit-line functions. A procedure for creating an upper and a lower limit line is at the end of this section.

Limit-Line Functions

Procedure for Creating an Upper Limit Line

This procedure demonstrates how to create a sample upper limit line for the CAL OUT signal and activate testing. Detailed descriptions of the limit-line functions follow this procedure.

- 1 Press **PRESET**.
- 2 Set the center frequency and span by pressing **FREQUENCY**, 300 **MHz**, and **SPAN**, 500 **MHz**.
- 3 Connect the spectrum analyzer CAL OUT and INPUT 50 Ω on the spectrum analyzer using an appropriate cable. (The calibration signal is used as the “test” signal for this demonstration.)

NOTE:

If the amplitude units are anything other than dBm at this time, change the amplitude units to dBm for this demonstration. Press **AMPLITUDE**, **More 1 of 2**, **Amptd Units**, **dBm**.

- 4 Press **DISPLAY**, **Limit Lines** to access the limit-line menus.

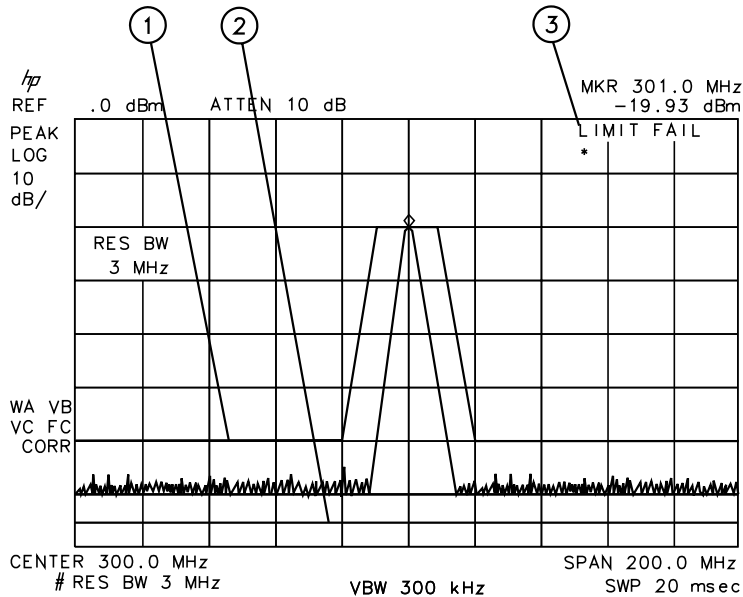

Figure 42 Typical Limit-Line Display

Item	Description of Items in Figure 42
1	Upper limit line
2	Lower limit line
3	Screen message

- 5 Press **Edit Limit** then **Edit Upper** to create an upper limit line.

The table defaults to frequency parameters, the second column should be labeled **START_FREQ**. If it is labeled **START_TIME**, press **More 1 of 2**, **EDIT DONE**, and **Edit Limit**. Press **LIMITS FRQ TIME** so that **FRQ** is underlined. **LIMITS FRQ TIME** specifies that the limit line parameters be entered in either frequency or time.

NOTE:

To clear an existing limit-line table, press **More 1 of 2**. Then press **PURGE LIMITS** two times.

After pressing **PURGE LIMITS** the first time, the message **If you are sure, press key again to purge data** will appear. Pressing **PURGE LIMITS** a second time purges the limit-line table. **PRESET** turns limit-line testing off (if it is on), but does not clear an existing limit-line table.

- 6 Press **Edit Upper** to edit or create an upper limit line.

- 7 The table defaults to fixed parameters, the upper right corner of the table should be labeled **FIXED**. If it is labeled **RELATIVE**, press **More 1 of 2**. Then press **LIMITS FIX REL** so that **FIX** is underlined. **LIMITS FIX REL** specifies whether or not the limit line is relative to the spectrum analyzer center frequency and reference-level settings.

When time parameters are used, the **RELATIVE** format only affects the amplitude part of the coordinate pairs. The time parameters are always fixed beginning at the left edge of the graticule.

- 8 Specify the first limit-line segment to begin at 50 MHz and have an amplitude of -60 dBm by using the following key sequence:

SELECT FREQ 50 MHz 60 **-dBm** **FLAT**

NOTE:

The coordinates for the second point must be entered before the first and limit-line segment is displayed.

- 9 Enter the second limit-line segment by pressing the following keys: 250 MHz 60 -dBm **SLOPE**.

Limit-Line Functions

NOTE:

Table entries can be edited if you make a mistake. To edit an existing segment, use **SELECT SEGMENT** to specify the segment. Use **SELECT FREQ**, **SELECT AMPLITUDE**, or **SELECT TYPE** to specify the column you wish to edit.

- 10 Specify the third limit-line segment by pressing the following keys: 400 MHz 15 -dBm **FLAT**.

You may notice that the end coordinate of segment three is drawn to a point off the top of the spectrum analyzer display. This assures that no trace data beyond the end of the limit line will cause the test to fail.

- 11 Specify the fourth limit-line segment by pressing the following keys: 600 MHz 15 -dBm **POINT**.

Since the limit line in this procedure has only four segments specified, the frequency value of segment four (the last segment) is set to 600 MHz, which is greater than the stop frequency of the display.

- 12 Press **More 1 of 2**, then **EDIT DONE** when all the segments have been entered.
- 13 Press **LMT TEST ON OFF** so that **ON** is underlined. This turns the limit testing on. For example, **LIMIT FAIL** is displayed because the calibration signal exceeds the limit line.
- 14 Disconnect the CAL OUT from the spectrum analyzer 50Ω INPUT. **LIMIT PASS** is displayed since no signal exceeds the limit line.

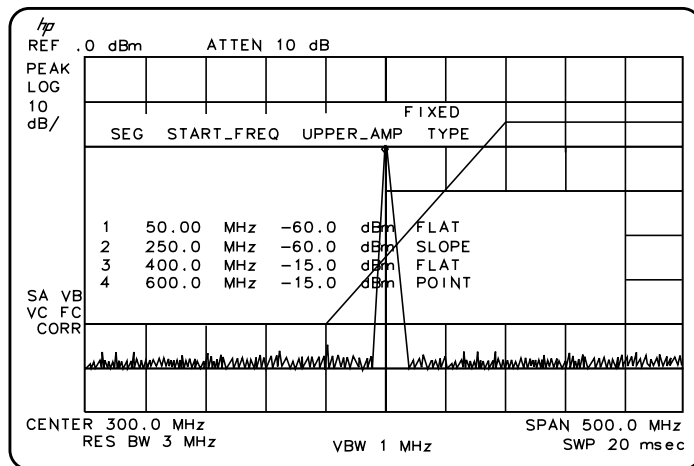

Figure 43 The Completed Limit-Line Table

Limit-Line Functions

This section describes the limit-line functions in the order that they are usually used.

Editing, Creating, or Viewing a Limit-Line

Pressing **(DISPLAY)**, then **Limit Lines** accesses the softkey menus used for creating a limit line.

Press **Edit Limit** to edit an existing limit-line table or. If no limit-line table currently exists this will allow you to create one.

If a limit line exists currently, and you would like to purge it and create a new one, press **Edit Upper**, and **More 1 of 2**. Then press **PURGE LIMITS** two times to clear the existing limit-line table and access the limit-line editing menu.

NOTE:

After pressing **PURGE LIMITS** the first time, the message **If you are sure, press key again to purge data** will appear. Pressing **PURGE LIMITS** a second time purges the limit-line table. **(PRESET)** turns limit-line testing off (if it is on), but does not clear an existing limit-line table.

Selecting the Type of Limit-Line Table

The **LIMITS FRQ TIME** key selects the type of limit line parameters. Parameters can be entered as frequency/amplitude coordinates, or as time/amplitude coordinates. Use the **LIMITS FRQ TIME** key, to underline the desired choice of either frequency or time parameters. Frequency is the default selection. If **TIME** is selected **SELECT TIME** will replace **SELECT FREQ** in the Edit Limit menus.

The second column of the limit line table is labeled **START_FREQ** when frequency is selected. It is labeled **START_TIME** when time is selected.

The **LIMITS FIX REL** key selects the type of limit line. There are two types of limit lines: fixed and relative. Fixed limit lines contain only absolute amplitude and frequency (or time) values. Relative limit lines consist of frequency values that are referenced to the spectrum analyzer center frequency and amplitude values that are relative to the analyzer reference level. The relative setting does not affect time values. They always begin at the left edge of the graticule.

Limit-Line Functions

As an example fixed versus relative limit lines, if a limit line is specified as fixed, entering a limit-line segment with a frequency coordinate of 300 MHz displays the limit-line segment at 300 MHz. If the same limit-line table is specified as relative, it is displayed relative to the spectrum analyzer center frequency and reference level. If the center frequency is at 1.2 GHz, a relative limit-line segment with a frequency coordinate of 300 MHz will display the limit-line segment at 1.5 GHz. If the amplitude component of a relative limit-line segment is -10 dB and the spectrum analyzer reference level is -15 dB, then -10 dB is added to the reference-level value and the amplitude component of the limit line will be at -25 dB.

RELATIVE is displayed in the limit-line table when the limit-line type is relative; **FIXED** is displayed when the limit-line type is fixed. A limit line entered as fixed may be changed to relative, and one entered as relative may be changed to fixed. When the limit-line type is changed, the frequency and amplitude values in the limit-line table are modified by the current center frequency and reference level settings to keep the limit line in the same position on the spectrum analyzer.

Selecting the Limit-Line Table Format

Press **Edit Upper**, **Edit Lower**, **Edit Up/Low**, or **Edit Mid/Delt** to edit or create a limit-line table. Each of the edit softkeys represents a different type of limit-line table format. The choice of edit softkey depends upon whether you want an upper limit line only, a lower limit line only, or both an upper and a lower limit line. If you want both lower limit lines, then the characteristics of the limit lines being entered affect your choice of using the upper/lower or mid/delta functions.

The four limit-line table formats are described below:

- The upper limit-line table format is accessed by **Edit Upper**. With the upper limit-line table format, the coordinates of only the upper limit line are displayed for editing; lower limit-line coordinates are not specified. Even if lower limit-line values exist or the values had been entered as an upper and lower limit-line table, the upper limit-line values are treated as a separate table from the lower limit-line values. Upper limit-line entries can have independent frequency and amplitude coordinates from lower limit-line table entries.
- The lower limit-line table format is accessed by **Edit Lower**. With the lower limit-line table format, the coordinates of only the lower limit line are displayed for editing; upper limit-line coordinates are not specified. Even if upper limit-line values exist or the values had been entered as an upper and lower limit-line table,

the lower limit-line values are treated as a separate table from the upper limit-line values. Lower limit-line entries can have independent frequency and amplitude coordinates from upper limit-line table entries.

- The upper and lower limit-line table format is accessed by **Edit Up/Low**. With the upper and lower limit-line table format, the upper and lower limit-line coordinates can be entered at the same time: the frequency (or time), upper amplitude, lower amplitude, and type are specified. The frequency (or time) and upper amplitude comprise the coordinate point for the upper limit line; the frequency (or time) and lower amplitude value comprise the coordinate point for the lower limit line. It is not necessary to specify both an upper- and lower-amplitude component for every frequency component. Three asterisks in the table indicate that an amplitude value has not been entered for the segment.
- The mid/delta limit-line table format is accessed by **Edit Mid/Delt**. Like the upper and lower limit-line table format, the mid/delta limit-line table format provides a means of specifying the upper and lower limit lines at the same time. Unlike the upper and lower table format, the amplitude values are specified as a middle amplitude value with a delta: the upper and lower limit lines are then drawn at an equal positive and negative distance from the middle amplitude. With the mid/delta format, the frequency (or time) and the mid-amplitude plus the delta comprise the upper limit line; the frequency (or time) and the mid-amplitude minus the delta comprise the lower limit line. The difference between the mid/delta format and the upper/lower format is the way the amplitude values are entered; however, in both formats, the frequency coordinate begins a segment. The mid/delta format can be used if the upper and lower limit lines are symmetrical with respect to the amplitude axis.

NOTE:

Editing a limit line table can be done using a different format than the one that was used for creating it.

Selecting the Segment Number

Pressing **SELECT SEGMENT** specifies the segment number to be entered or edited. Limit lines are created by entering frequency or time values and amplitude values into a limit-line table. The frequency/time and amplitude values specify a coordinate point from which a limit-line segment is drawn. The coordinate point is the lowest frequency or time point of the line segment. Limit lines are constructed from left to right. The segment is defined by its beginning point. See Figure 44 on page 102.

Limit-Line Functions

NOTE:

Up to 20 segments can be specified for an upper or lower limit-line table.

When entering a limit-line segment, the frequency/time and amplitude values will be listed as asterisks (***) until new values are entered. The new segment will be listed last until both the frequency (or time) and the amplitude values have been entered. Once the frequency/time and an amplitude value are entered, the segment will be sorted into the limit-line table according to frequency or time.

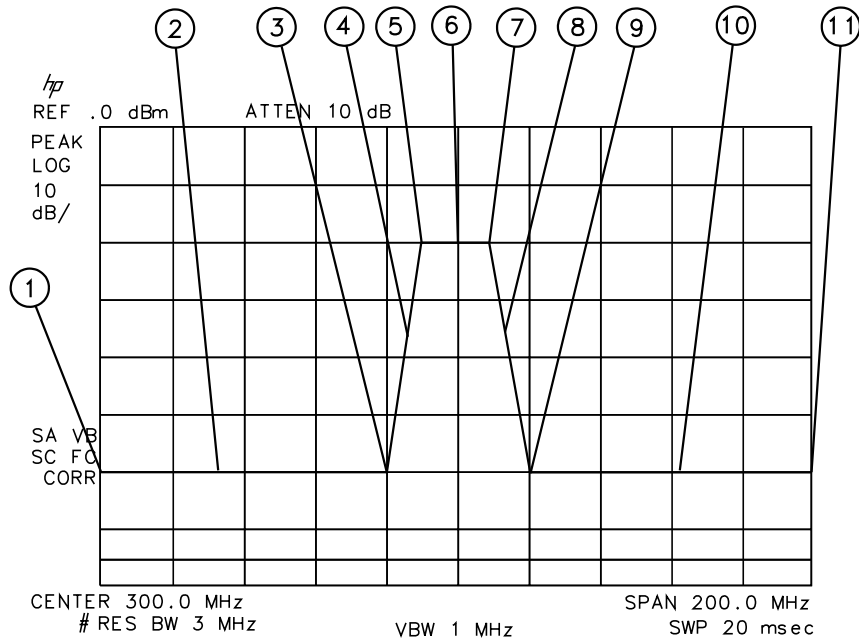

Figure 44 Limit-Line Segments

Item	Description of Items in Figure 44
1	Frequency and amplitude coordinate that starts the first segment.
2	First segment.
3	Frequency and amplitude coordinate that starts the second segment.
4	Second segment.

Item	Description of Items in Figure 44
5	Frequency and amplitude coordinate that starts the third segment.
6	Third segment.
7	Frequency and amplitude coordinate that starts the fourth segment.
8	Fourth segment.
9	Frequency and amplitude coordinate that starts the fifth segment.
10	Fifth segment.
11	Frequency and amplitude coordinate that starts the sixth segment.

Selecting the Frequency or Time Coordinate

Press **SELECT FREQ**, then enter a frequency value, or press **SELECT TIME** and enter a time value, for the segment. Regardless of the table format, a frequency/time coordinate must be specified.

NOTE:

Limit line coordinates may be entered in terms of either frequency and amplitude, or time and amplitude. Press **LIMITS FRQ TIME** until the desired choice of either frequency or time has been selected (underlined). If **TIME** has been selected as the limit line parameter **SELECT TIME** will replace **SELECT FREQ** in the Edit Limit menus.

Selecting the Amplitude Coordinate

In the previous procedure, pressing **SELECT AMPLITUD** and then entering an amplitude value, specified the amplitude coordinate for the upper limit line. The limit-line table formats dictate how the amplitude values are treated:

- With the upper limit-line table format, one amplitude component (representing an upper limit-line segment) is specified per frequency/time component. The amplitude value is entered by pressing **SELECT AMPLITUD**, entering an amplitude value, and pressing a units key.
- With the lower limit-line table format, one amplitude component (representing a lower limit-line segment) is specified per frequency/time component. The amplitude value is entered by pressing **SELECT AMPLITUD**, entering an amplitude value, and pressing a units key.
- With the upper/lower limit-line table format, two amplitude components (one each for the upper and lower limit-line segments) can be specified per frequency

Limit-Line Functions

or time component. It is not necessary to specify both an upper and a lower amplitude value. Specifying only upper amplitude values results in an upper limit line, but not a lower limit line. Omitting an amplitude point on one limit line does not affect the other limit line. The amplitude of the upper limit line is entered by pressing **SELECT UPR AMPL**, entering an amplitude value, and pressing a units key. The amplitude of the lower limit line is entered by pressing **SELECT LWR AMPL**, entering an amplitude value, and pressing a units key.

- With the mid/delta limit-line table format, two amplitude components (one representing a mid-amplitude value, one representing a deviation [positive and negative values] from either side of this value) is specified per frequency component. If no deviation is entered, the deviation defaults to zero. The middle amplitude value is entered by pressing **SELECT MID AMPL**, entering an amplitude value, and pressing a units key. The deviation is entered by pressing **SELECT DLT AMPL**, entering an amplitude value, and pressing a units key.

NOTE:

Frequency or amplitude values that are not within the limit-line range will be modified. For example, a frequency value of 60 GHz will be modified to 30 GHz.

Selecting the Segment Type

Press **SEGMENT TYPE**, then **FLAT**, **SLOPE**, or **POINT** to specify the segment type. The segment type determines how to connect the coordinate point of the current line segment with the coordinate point of the next line segment. The segment type determines whether the line segment is horizontal, vertical, sloped, or a single point. The three segment types are:

- 1 Flat draws a zero-slope line between the coordinate point of the current segment and the coordinate point of the next segment, producing limit-line values equal in amplitude for all frequencies or times between the two points. If the amplitude values of the two segments differ, the limit-line will “step” to the value of the second segment. See Figure 45 on page 105.
- 2 Slope draws a straight line between the coordinate point of the current segment and the coordinate point of the next segment, producing limit-line values for all frequencies between the two points.
- 3 Point specifies a limit value for the coordinate point. It specifies a limit at a single frequency or time, and for no other frequency/time points. For an upper limit line, a point segment is indicated by a line drawn from the coordinate point, vertically off the top of screen. For a lower limit line, a point segment is indicated by a line drawn from the coordinate point, vertically off the bottom of screen. The point segment type should be used as the last segment in the limit-line table. However, if the last segment in the table is not specified as the point segment type, an implicit point is automatically used. (If a visible point segment at the right-hand edge of the display is not desired, add an explicit last point segment to the limit-line table that is higher in frequency than the stop frequency.)

Figure 45 demonstrates the different segment types.

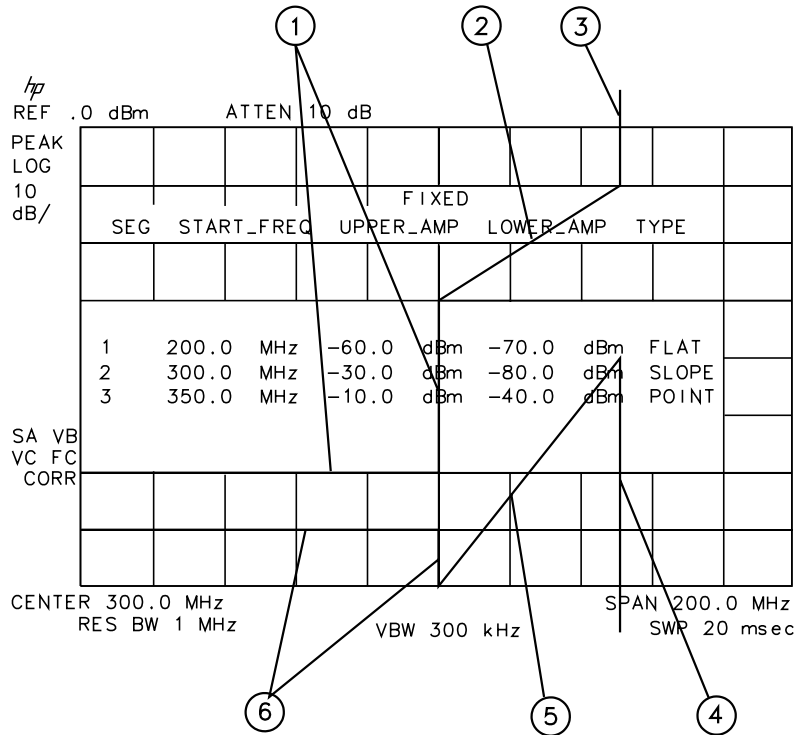

Figure 45 Segment Types

Item	Segment Types
1	Flat (upper limit line)
2	Slope (upper limit line)
3	Point (upper limit line)
4	Point (lower limit line)
5	Slope (lower limit line)
6	Flat (lower limit line)

Limit-Line Functions

Completing Table Entry and Activating Limit-Line Testing Pressing **EDIT DONE** blanks the limit-line table from the screen and accesses the menu with **LMT TEST ON OFF** and **LMT DISP Y N AUTO** softkeys.

Pressing **LMT TEST ON OFF** turns the limit-line testing on and off.

Pressing **LMT DISP Y N AUTO** (Y) turns the limit lines display on. Pressing **LMT DISP Y N AUTO** (N) turns the limit lines display off. Pressing **LMT DISP Y N AUTO** (AUTO) sets the limit line display to match the limit line test function. With AUTO underlined the limit lines are only displayed when limit line testing is turned on.

Saving or Recalling Limit-Line Tables Pressing **(DISPLAY)** then **Limit Lines** accesses **SAVE LIMIT** and **RECALL LIMIT**. These softkey functions provide an easy way to save or recall current limit-line tables. **SAVE LIMIT** saves the current limit-line tables in the current mass storage device (either spectrum analyzer memory or a memory card). To determine the current mass storage device, press **SAVE LIMIT**. If **MAX REG #** appears on the spectrum analyzer display, the current mass storage device is analyzer memory. If **PREFIX=** is displayed, the memory card is the mass storage device. Enter a register number, then press **(ENTER)** to save the current limit-line table in the current mass storage location.

EXT PAD YES NO recalls limit-line tables from the current mass storage device (either spectrum analyzer memory or a memory card). To determine the current mass storage device, press **RECALL LIMIT**. If **MAX REG #** appears on the spectrum analyzer display, the current mass storage device is analyzer memory. If **PREFIX=** is displayed, the memory card is the mass storage device. To recall a limit line, enter the register number that the limit-line table was saved under, then press **(ENTER)**. When recalling a limit line from the memory card, it is necessary that the current prefix matches the prefix that the limit line was stored with. Use **Change Prefix** to change the current prefix.

Procedure for Creating an Upper and Lower Limit Line

This is a basic procedure for creating a sample of upper and lower limit lines. The CAL OUT signal is used for the test signal.

- 1 Press **PRESET**.
- 2 Since this procedure uses the calibration signal as the test signal, connect the spectrum analyzer CAL OUT to the INPUT 50 Ω with an appropriate cable.
- 3 Set the spectrum analyzer controls as follows:
 - FREQUENCY** 300 MHz
 - SPAN** 50 MHz
 - BW** 3 MHz
- 4 Press **DISPLAY** and **Limit Lines** to access the limit-line menus.
- 5 At this point you may need to do the following:
 - a To save the current limit-line table, press **SAVE LIMIT** and enter the register number. Then press **ENTER**.
 - b To clear an existing limit-line table, press **Edit Limit**, **Edit Upper**, and **More 1 of 2**. Then press **PURGE LIMITS** two times.
- 6 (If necessary, press **Edit Limit** to access the **LIMITS FRQ TIME** softkey.) Press **LIMITS FRQ TIME** so that FRQ is underlined to select the frequency type of limit line, if it is not already selected.)
- 7 Press **Edit Up/Low** to create upper and lower limit lines simultaneously.
- 8 Press **More 1 of 2**, **LIMITS FIX REL** so that FIX is underlined to select the fixed type of limit line (if it is not already selected.)
- 9 Specify the first limit-line segment by using the following key sequence:
 - SELECT FREQ** 275 MHz
 - 60 -dBm
 - 75 -dBm
 - FLAT**
- 10 Repeat the above step for the values listed in the following table to complete the limit-line table. (It is not necessary to repeat the **SELECT FREQ** softkey for successive entries.)

Limit-Line Functions

Segment Number	Frequency	Upper Amplitude	Lower Amplitude	Type
2	290 MHz	-60 dBm	-75 dBm	Slope
3	295 MHz	-15 dBm	-75 dBm	Slope
4	297 MHz	-15 dBm	-75 dBm	Slope
5	300 MHz	-15 dBm	-29 dBm	Slope
6	303 MHz	-15 dBm	-75 dBm	Slope
7	305 MHz	-15 dBm	-75 dBm	Slope
8	310 MHz	-60 dBm	-75 dBm	Flat
9	400 MHz	-60 dBm	-75 dBm	Point

NOTE:

When entering a limit-line segment, the frequency, and amplitude values will be listed as asterisks (***) until new values are entered. The new segment will be listed last until both the frequency and amplitude values have been entered. Once the frequency and at least one amplitude value are entered, the segment will be sorted into the limit-line table according to frequency.

To edit an existing segment, use **SELECT SEGMENT** to specify the segment.

Then use **SELECT FREQ**, **SELECT AMLPLITUD**, or **SELECT TYPE** to specify the column that you wish to edit.

- 11 Press **More 1 of 2**, then **EDIT DONE** when all values have been entered into the limit-line table.
- 12 Press **LMT TEST ON OFF** so that ON is underlined. **LIMIT PASS** is displayed on the spectrum analyzer screen if the measurement sweep is within the limit lines. **LIMIT FAIL** is displayed if the measurement sweep is not within the limit lines.

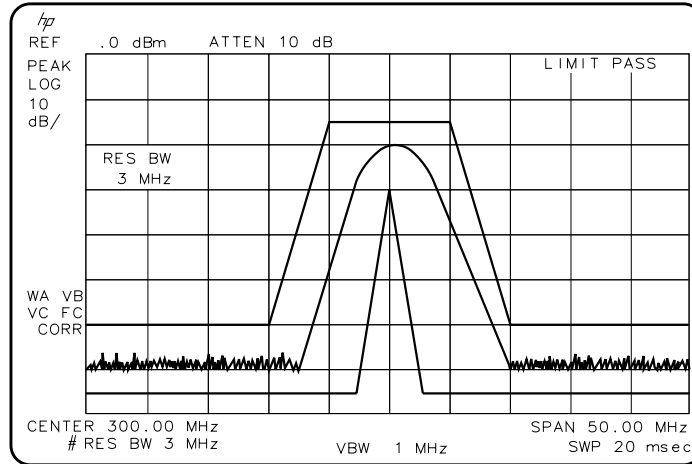

Figure 46 Upper and Lower Limit-Line Testing

To turn the limit-line testing on and off, use **LMT TEST ON OFF**. Use **PURGE LIMITS** to clear the limit-line tables. To remove the limit lines from the display, use **LMT DISP Y N AUTO**. Underlining Y displays the limit lines, N turns them off, and AUTO displays them if the testing is turned on or turns them off if testing is turned off.

Amplitude Correction Factors

This section provides an overview of amplitude correction, a procedure for creating amplitude-correction data, and descriptions of the amplitude-correction functions.

Amplitude corrections provide an easy way to adjust trace data with a set of amplitude and frequency parameters while the spectrum analyzer is sweeping the measurement range. Every measurement sweep of data is adjusted by the amplitude-correction values. When using the amplitude-correction functions, an **A** is displayed at the left-hand side of the graticule edge.

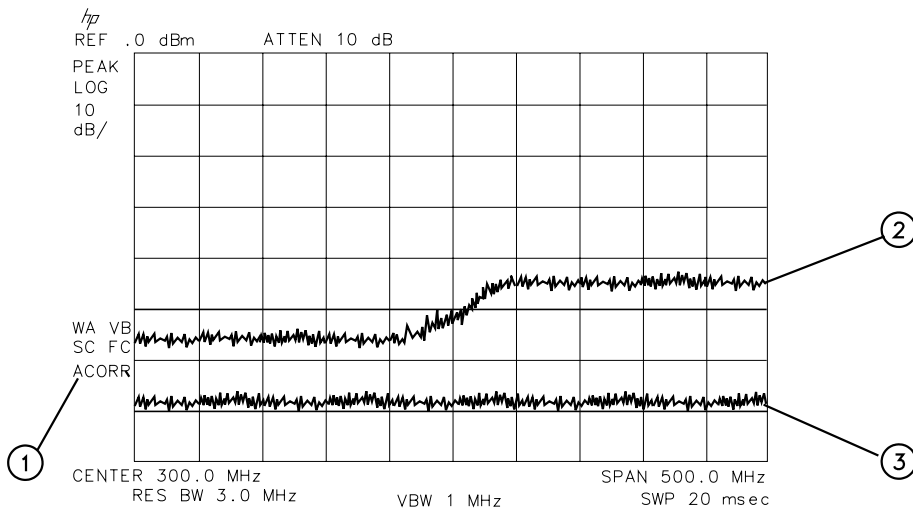

Figure 47 Amplitude-Correction Display

Item	Description of Items in Figure 47
1	Indicates amplitude-correction factors are on.
2	Amplitude corrections ON.
3	Amplitude corrections OFF.

Procedure for Creating Amplitude-Correction Factors

This procedure demonstrates how to create and activate amplitude-correction data. Detailed descriptions of the amplitude-correction functions follow this procedure.

- 1 Press **PRESET**.

NOTE:

A signal is not used in this procedure for demonstrating how to create amplitude-correction data. Disconnect any cable on the spectrum analyzer input.

- 2 Set the center frequency to 300 MHz and the span to 500 MHz by pressing:

FREQUENCY 300 **MHz**
SPAN 500 **MHz**

- 3 Press **CAL**, **More 1 of 4**, **More 2 of 4**, **More 3 of 4**, then **Amp Cor** to access the amplitude-correction menus.
- 4 Press **Edit Amp Cor** to access the editing menus for amplitude-correction factors.
- 5 To clear any existing amplitude-correction data, press **PURGE AMP COR** two times consecutively.

NOTE:

After pressing **PURGE AMP COR** the first time, the message **If you are sure, press key again to purge data** will appear. Pressing **PURGE AMP COR** a second time erases the amplitude-correction data.

- 6 Specify the first amplitude-correction point by pressing the following keys:

SELECT FREQ
50 **MHz**
12 **+dBm**

- 7 Specify the second amplitude-correction point by pressing the following keys:

250 **MHz**
10 **+dBm**

NOTE:

Table entries can be edited if you make a mistake. To edit an existing point, use **SELECT POINT** to specify the point. Then use **SELECT FREQ** or **SELECT AMPLITUDE** to specify the entry that you wish to edit.

- 8 Specify the third and fourth amplitude-correction points by using the following key sequence:

300 **MHz** 15 **+dBm**
350 **MHz** 22 **+dBm**

Amplitude Correction Factors

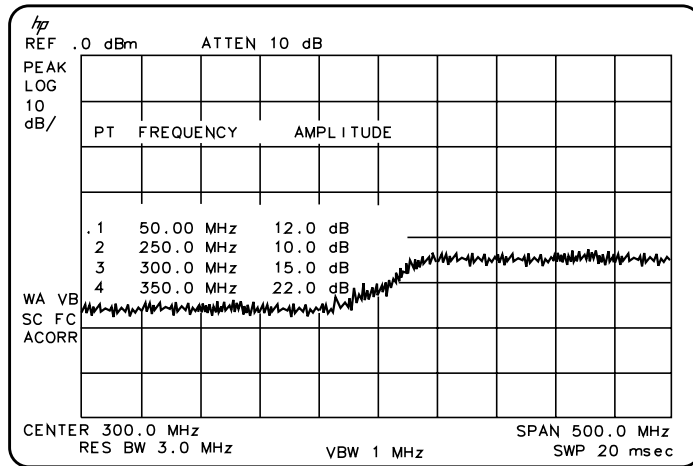

Figure 48 Completed Amplitude-Correction Table

9 Press **EDIT DONE** when all the points have been entered.

Use steps 10 and 11 to display corrected versus uncorrected amplitude trace data for trace comparison.

10 Display the amplitude-corrected trace in trace A by pressing the following keys:

TRACE
CLEAR WRITE A
VIEW A

11 Display the uncorrected amplitude trace in trace B by pressing the following keys:

TRACE A B C until B is selected
CLEAR WRITE B
CAL, **More 1 of 4**, **More 2 of 4**, **More 3 of 4**, **Amp Cor**
AMP COR ON OFF until OFF is selected

Amplitude-Correction Functions

This section describes the amplitude-correction functions in the order they are usually used.

Editing or Viewing the Amplitude-Correction Tables

Pressing **CAL**, **More 1 of 4**, **More 2 of 4**, **More 3 of 4**, **Amp Cor** accesses the softkey menus for creating an amplitude-correction table.

NOTE:

PRESET turns amplitude-correction factors off (if it is on), but does not clear an existing amplitude-correction table. Use **PURGE AMP COR** to clear an existing amplitude-correction table.

Press **Edit Amp Cor** to edit an existing amplitude-correction table or, if no amplitude-correction table currently exists, to create an amplitude-correction table.

Pressing **PURGE AMP COR** two times consecutively clears an existing amplitude-correction table.

Selecting the Amplitude-Correction Point

Pressing **SELECT POINT** specifies the amplitude-correction point to be entered or edited. Amplitude-correction data is constructed from left to right and is created by entering frequency and amplitude values into an amplitude-correction table. The frequency and amplitude values specify a coordinate point from which amplitude-corrections are interpolated. See Figure 49 on page 114. Up to 79 points can be specified for the amplitude-corrections table.

Making Measurements in Spectrum Analyzer Mode
Amplitude Correction Factors

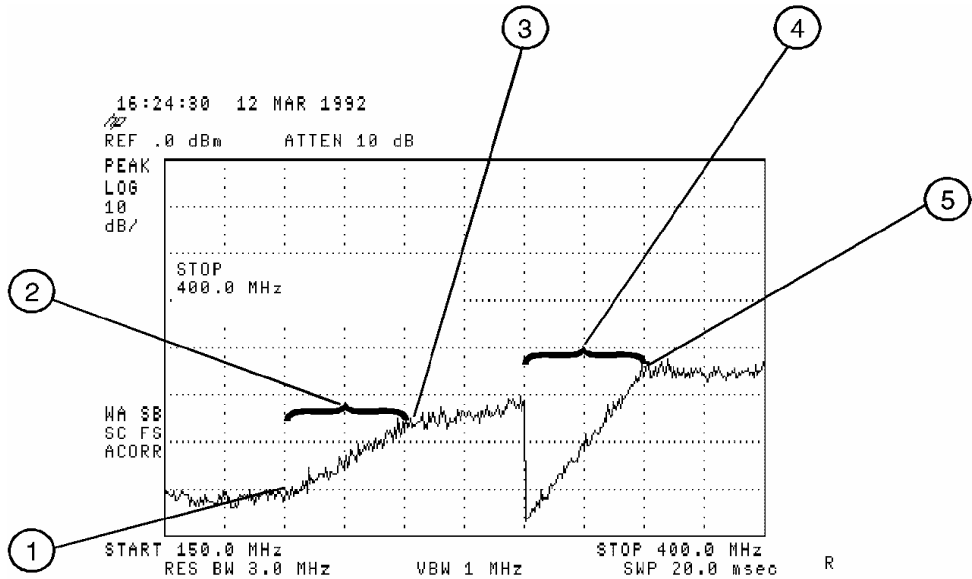

Figure 49 Amplitude-Correction Points

Item	Description of Items in Figure 49
1	Frequencies below first point use first amplitude level.
2	First segment interpolated with the 10 dB amplitude level.
3	Frequency and amplitude coordinate that starts the second segment.
4	Third segment interpolated with the -10 dB amplitude level.
5	Frequency and amplitude coordinate that starts the fourth segment.

Selecting the Frequency Coordinate

Press **SELECT FREQ**, then enter a frequency value for the point.

NOTE:

Only two entries per frequency are used. If more points with the same frequency are entered, only the first and last entries are used. All other amplitude values are ignored. See Figure 49 for an example of two entries at the same frequency.

When entering amplitude-correction data, the frequency and amplitude values will be listed as asterisks (***) until new values are entered. Once the frequency value is entered, the segment is immediately sorted into the table according to this value.

Selecting the Amplitude Coordinate

The amplitude value is entered by pressing **SELECT AMPLITUD**, entering an amplitude value, and pressing a units key.

NOTE:

Frequency or amplitude values that are not within range will be modified. For example, a frequency value of 60 GHz will be modified to 30 GHz.

Completing Table Entry and Activating Amplitude Corrections

Pressing **EDIT DONE** blanks the amplitude-correction table from the screen and accesses the menu with **AMP COR ON OFF**.

Pressing **AMP COR ON OFF** turns the amplitude corrections on and off.

Saving or Recalling Amplitude Correction Tables

Pressing **Amp Cor** under the **(DISPLAY)** key accesses **SAVE AMP COR** and **RECALL AMP COR**. These softkey functions provide an easy way to save or recall current amplitude-correction tables. **SAVE AMP COR** saves the current amplitude-correction table in the current mass storage device (spectrum analyzer memory or memory card). To determine the current mass storage device, press **SAVE AMP COR**. If **MAX REG #** appears on the spectrum analyzer display, the current mass storage device is analyzer memory. If **PREFIX=** is displayed, the memory card is the mass storage device. (Press **(SAVE)** or **(RECALL)**, **INTERNAL CARD** to change the current

Amplitude Correction Factors

mass storage device.) Press **EXT PAD YES NO**, enter a register number, then press **(ENTER)** to save the current amplitude-correction table in spectrum analyzer memory or on the memory card.

RECALL AMP COR recalls amplitude-correction tables from the current mass storage device (spectrum analyzer memory or memory card). To determine the current mass storage device, press **RECALL AMP COR**. If **MAX REG #** appears on the spectrum analyzer display, the current mass storage device is analyzer memory. If **PREFIX=** is displayed, the memory card is the mass storage device. (Press **(SAVE)** or **(RECALL)**, **INTERNAL CARD** to change the current mass storage device.) When recalling an amplitude-correction table from the memory card, it is necessary that the current prefix match the prefix that the table was originally stored with. Use **Change Prefix** to change the current prefix. To recall an amplitude-correction table, enter the register number that the table was saved under, then press **(ENTER)**.

Windows Display

The windows display feature is only available on the HP 8591E, HP 8593E, HP 8594E, HP 8595E, and HP 8596E. Windows display mode splits the spectrum analyzer display into two frequency or time displays.

When windows is first turned on, the top window will contain an inactive copy of the previous display. The lower window will be active and will display a subset of the frequency span of the upper window. The span of the lower window will be indicated on the upper window by two vertical lines called zone markers. The zone markers can be moved using the zone center and zone span softkeys to look at different portions of the upper window span.

The instrument state of the active window can be changed without affecting the state of the inactive window. The state of the active window will be used as the state of the spectrum analyzer for sweeping and updating trace data.

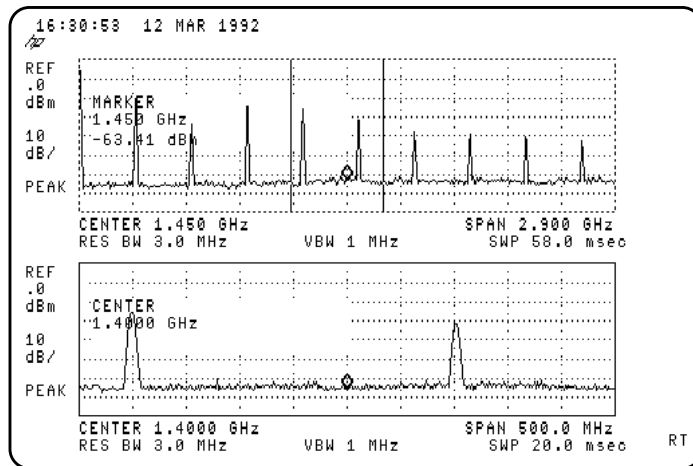

Figure 50 Windows Display Mode

Example: Use the windows display format to view the calibrator signal.

- 1 Connect the CAL OUT signal to the spectrum analyzer INPUT 50Ω. Press **PRESET**, **FREQUENCY**, **START FREQ** 0 **(HZ)**, **STOP FREQ** 2 **(GHZ)**.

Windows Display

- Turn on the windows display by pressing the WINDOWS **(ON)** key. The active window is indicated by a solid line around the display, rather than a broken line. Press **ZONE CENTER** use the knob or step keys to move the zone to include one of the harmonics. Notice that the span marked by the zone markers in the upper window is shown as a full display in the lower window.

NOTE:

The upper window is not active so the trace is not updated, though the zone position is updated. The upper window must be activated by pressing WINDOWS **(NEXT)** to update the trace data.

- Press **ZONE PK RIGHT**. The spectrum analyzer identifies the first signal to the right of the zone and moves the zone so that it is centered around the new signal.
- Press **ZONE SPAN** and use the knob, step keys, or the data entry keys to change the zone span to include two signals. If the lower window is active you will notice that the span changes corresponding to the changes in the zone marked on the upper window. (If the lower window is not active press WINDOWS **(NEXT)** to make it active.)
- Press **ZONE PK RIGHT** and **ZONE PK LEFT** and observe the movement of the zone and the changes in the lower window.
- Press WINDOWS **(ZOOM)**. Now a full-sized display of the lower window will be displayed. Notice the increase in the displayed annotation.
- Pressing WINDOWS **(NEXT)** activates the upper window. A full- sized display of it will be shown, and the inactive lower window will not be displayed. Press WINDOWS **(NEXT)** again to activate the lower window and display it again. Notice that the zone markers can be used to tell which window is active and being displayed while in the zoom state.
- Press WINDOWS **(ZOOM)** to return to the dual windows display. The lower window will still be active.
- Press **WINDOWS OFF** and the spectrum analyzer returns to normal operation with the active window as the spectrum analyzer state.
- Pressing WINDOWS **(ON)** at this point turns the windows display format on again with the current display as the new upper window. A new lower window will be generated based on the zone in the upper window.

NOTE:

Markers and limit lines can be used in both windows, but they must be turned on independently in each window. The current limit lines will be common to both windows.

Gate Utility (Option 105 only)

The time gate allows you to control when a spectrum analyzer measurement begins and the length of time during which the measurement is made. The time gate is an RF signal switch that permits signal into the spectrum analyzer only while the switch, or gate, is closed. Since the spectrum analyzer receives the signal only when passed through the gate, it will only display the measurement results from the portion of the signal selected by the time position of the gate closure. The time gate acts as a time filter, rejecting signals and spectra not occurring at the desired time.

The time gate utility simplifies the use of the time gate. In the gate utility, the spectrum analyzer can display the time domain and the frequency domain simultaneously, using two separate windows. The user is able to adjust the time position of the gate closure relative to the input signal, using interactive graphic tools in the gate utility. The gate position relative to the signal is clearly shown in the time domain window. The spectral effects corresponding to an adjustment of the gate time position are displayed in the frequency domain window. Tools are provided to aid the user in determining the best gate position, and optimizing the spectrum analyzer settings for the input signal.

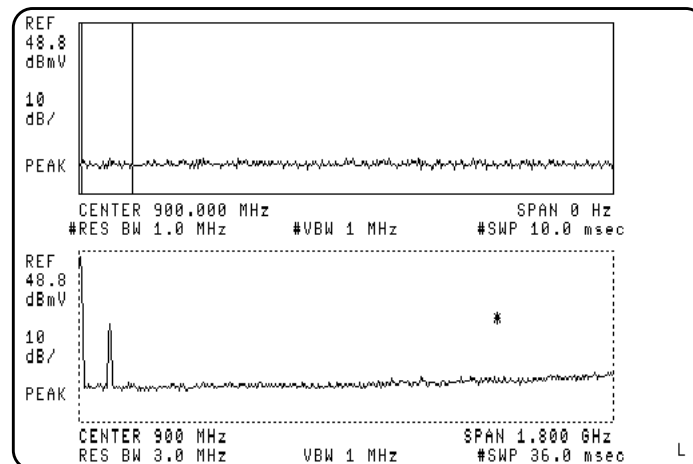

Figure 51 Time-Gate Utility Display

Gate Utility (Option 105 only)

Gate utility features include:

- Displays time and frequency domains simultaneously.
- Measures continuously.
- Interactively controls and displays the gate's position in time.
- Optimizes spectrum analyzer settings for pulsed RF signals automatically.

NOTE:

Option 105, time gate, is required. Option 101, fast ADC, is recommended providing fast sweep times, 20 μ sec full span, and yielding fine-time resolution. (Sweep times down to 20 msec are available without Option 101.)

The gate utility provides tools to make pulsed RF measurements easy. If the user enters the pulse width, pulse repetition interval, and gate length, the gate utility will automatically optimize the resolution bandwidth, sweep time, and video bandwidth for these pulse parameters. Coupling the spectrum analyzer settings to pulse characteristics allows easy, accurate pulsed signal measurements.

The types of signals that can be measured using the time gate function include:

- Pulsed RF signals
- Time domain multiple access (TDMA) communication system signals
- Interleaved or intermittent signals
- Signals with transient spectra

Time critical signals are present in many different applications. A few of the applications are listed below:

- Digital cellular communication systems require measurements on pulse modulated TDMA signals. Measurements must be accurately aligned with the time division multiple access (TDMA) burst of the communication carrier. The time gate can position spectrum analyzer measurement to assess TDMA burst timing and the quality of the burst modulation.
- Rotating head devices, such as VCRs and hard disks, have time interleaved signals multiplexed from alternate recording tracks on the storage media. The time gate can isolate the spectrum due to a single recording track.
- Tests required for mobile communication systems often require that the transient spectrum, due to pulse modulation, be excluded from measurement results.

Example: Measure a Pulsed RF signal.

- 1 The rear panel GATE OUTPUT must be connected to EXT TRIG INPUT.

- 2 A TTL trigger signal must be connected to GATE TRIGGER INPUT on the rear panel. If no trigger is present an error message is displayed and the gate utility will not be activated.
- 3 Press **PRESET**. Connect a pulsed RF signal to the spectrum analyzer INPUT 50 Ω .
- 4 Press **FREQUENCY** and enter the frequency of your input signal to place the signal at the spectrum analyzer center frequency.
- 5 Press **AMPLITUDE**, **PEAK SEARCH**, **MKR →** and **MARKER → REF LVL** to bring the signal to the top of the display.
- 6 Access the gate utility by pressing **SWEEP**, **Gate Control**, and **GATE UTILITY**.

NOTE:

If the gate menus are exited without turning the gate utility off (by pressing another front panel key), press the **SWEEP** key twice to return to the last gate utility menu used.

- 7 Press **Define Time** to set up the time domain window (the upper window.) Change the sweep time using the **T WINDOW SWP TIME** softkey so that the pulses are displayed. Press **SWEEP DELAY** and use the knob to center the pulses in the upper window.
- 8 The trigger marker reads out the time from the rear panel gate trigger point to the current marker position. Turn the trigger marker on by pressing **TRIG MKR ON OFF** (ON) and use the knob to move the trigger marker to the edge of the pulse. The marker readout indicates the position of the edge relative to the rear panel trigger. The trigger marker may be used to perform “settling time” measurements on the rising or falling edges of a digital communications signal. (Settling time is the time from the trigger to 90 percent of the stable pulse on/off value.)
- 9 Press **Main Menu** to exit the define time menu.
- 10 Press **Define Gate**. Use the **GATE DELAY** and **GATE LENGTH** keys to position the gate. Once gate delay or gate length are activated, use the knob and data entry keys can be used to position the two vertical gate markers. Select a time interval within the last half of the pulse is selected.
- 11 Turn the gate on by pressing **GATE ON OFF** so that ON is underlined. This activates the frequency domain window, which is the lower window. The spectrum selected with the current gate position can now be viewed in the frequency domain window. Press **Main Menu**.

Gate Utility (Option 105 only)

- 12 The resolution bandwidth, video bandwidth, and sweep time are not optimized, so the frequency display may not look correct. There may be signal dropouts or poor frequency resolution. This can be corrected by entering the pulse parameters and turning on the coupling.

The gate utility can optimize the setting of resolution bandwidth if the user enters the value of the pulse width and turns on the coupling. The video bandwidth will be optimized if the gate length is entered and coupled. The sweep time is optimized when the pulse repetition interval is entered and coupled.

Press **Define Coupling**. Then press **Pulse Param** to enter the pulse parameters. (This activates the time domain window and turns off the time gate.) If pulse parameters have previously been entered, the values will be displayed.

- 13 Use the **ENTER REF EDGE**, **ENTER WIDTH**, and **ENTER PRI** softkeys to enter the pulse parameters. These parameter entry tools allow pulse parameters to be entered using a marker or through the keypad. Press **Previous Menu** to return to the coupling menu.
- 14 Press **CPL RBW ON OFF** (ON) to turn on the resolution bandwidth coupling. Press **CPL VBW ON OFF** (ON), and **CPL SWP ON OFF** (ON) to turn on the video bandwidth and sweep time coupling.
- 15 Press **Main Menu** and look at the signal in the time domain window.
- 16 Press **UPDATE TIME FREQ** so that FREQ is underlined or press **(NEXT)**, to activate the frequency window instead of the time domain window. (If the gate was not on when the user left the frequency window, it may be necessary to press **Define Gate** and **GATE ON OFF** (ON) to turn the gate on again.)

NOTE:

If the gate menus are exited without turning the gate utility off (by pressing another front panel key), press the **(SWEEP)** key twice to return to the last gate utility menu used.

Time-Gating (*Option 105 only*)

NOTE:

Option 101, fast time domain sweep, is recommended in addition to Option 105, because it significantly increases the resolution available in the time domain. With Option 101, sweep times (in zero span) as fast as 20 μ s can be used, otherwise the maximum sweep time is limited to >20 ms.

The measurement procedures in this section explain how to use the time gate capability without the convenience of the Gate Utility. The Gate Utility provides the user with simultaneous displays of the frequency and time domain to assist in setting up and manipulating the time gate. See ‘Gate Utility (Option 105 only)’ on page 119 for information.

This section provides the following information:

- Introduces the time-gated spectrum analyzer capability.
- Explains how to use Option 105 to view a pulsed RF signal.
- Explains how to use the self-calibration routines with Option 105.
- Explains how to perform a functional check of Option 105.

Introducing the Time-Gated Spectrum Analyzer Capability

As the spectrum analyzer takes a measurement sweep, it displays a specific frequency as it sweeps across the frequency range of the spectrum analyzer. Since signals can vary in time, the spectrum analyzer can miss an event at one frequency because it is sweeping at a different frequency when the event occurs. With Option 105, the time-gated spectrum analyzer capability, the spectrum analyzer can provide a “window” of what is going on with a signal at any specific time, since a spectrum analyzer with Option 105 has the capability to selectively acquire data based on an external trigger signal. The “window” represents a periodic timed event during which data acquisition is enabled.

The following figures demonstrate how the time gate can be used to view a signal. For example, you could have two signals at the same frequency in alternating time slots so they can share a common system. You can use an oscilloscope to determine whether there are two signals. See Figure 52.

Time-Gating (Option 105 only)

However, you could not use a standard spectrum analyzer since both signals would contribute to the displayed frequency spectrum. By using the time-gate functions of Option 105, you can use a spectrum analyzer to mask out one signal at a time and measure each of the two signals separately. See Figure 53 on page 125.

NOTE:

When Option 105 is enabled, it interrupts the internal signal path of the spectrum analyzer, so several spectrum analyzer functions may not be available under all conditions. These conditions include: marker noise (**MK NOISE ON OFF**), sample detection while in the frequency span mode, quasi-peak detection (Option 103), and AM/FM demodulation and TV sync trigger (Option 102). The marker counter function (**MK COUNT ON OFF**) is not directly affected by the operation of Option 105, but many signals that are appropriate for time-gating (for example, pulsed RF signals) will not be counted correctly by the marker counter function.

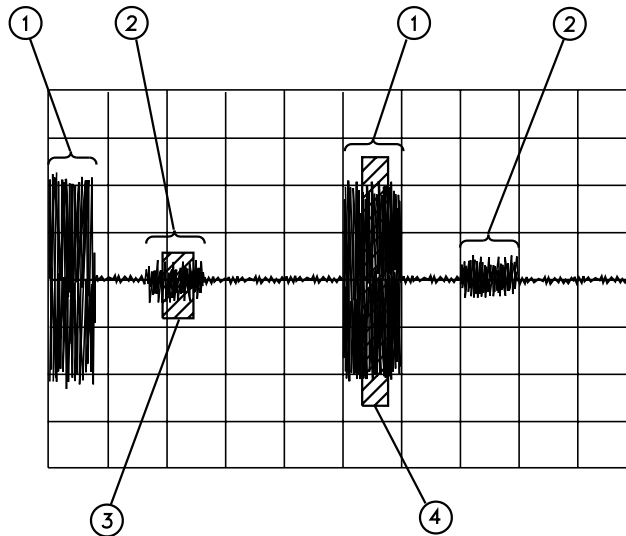

Figure 52 Viewing Time-Sharing of a Frequency with an Oscilloscope

Item	Description of Items in Figure 52
1	First signal.
2	Second signal.

Item	Description of Items in Figure 52
3	When the time gate will be actively viewing the second signal.
4	When the time gate will be actively viewing the first signal.

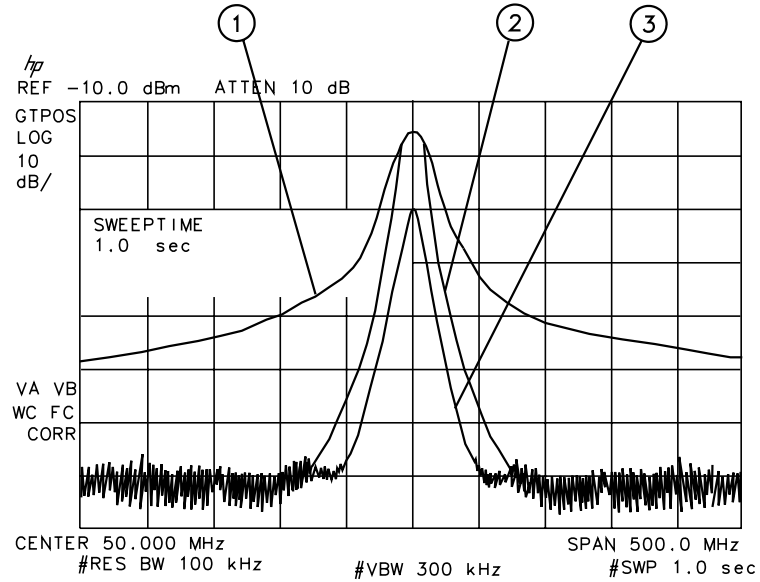

Figure 53 Viewing Time-Sharing of a Frequency with a Spectrum Analyzer

Item	Description of Items in Figure 53
1	Trace display without the time-gate function on.
2	Trace display of the first signal, with the time gate on.
3	Trace display of the second signal, with the time gate on.

Using the Time-Gated Spectrum Analyzer Capability to View Pulsed RF

This example demonstrates how to use Option 105 to view two different pulsed RF signals. The signals are at the same frequency, but they interleave in time. (This example uses the time gate function without using the gate utility.)

To use Option 105 to view the amplitude of a pulsed RF signal accurately, the spectrum analyzer settings of the sweep time, resolution bandwidth, video bandwidth, gate delay, and gate length must be set correctly. To set the spectrum analyzer settings correctly, you must determine the pulse repetition interval, pulse width, and signal delay (if any) of the pulsed RF signal. Figure 54 shows an example of two pulsed RF signals.

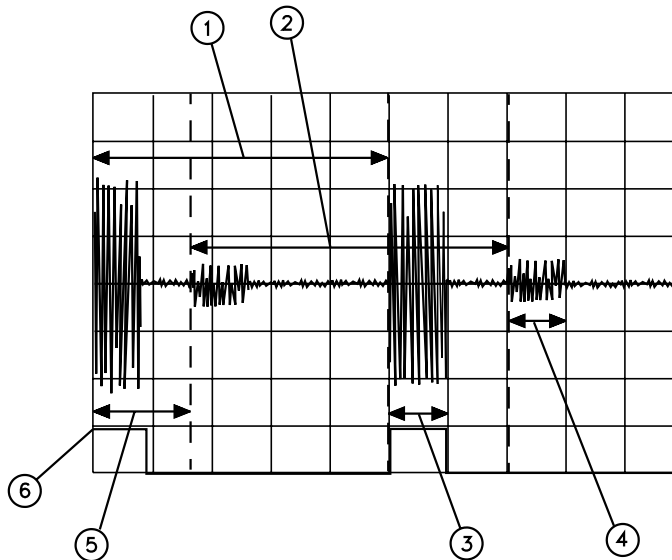

Figure 54 Pulse Repetition Interval and Pulse Width (with Two Signals Present)

Item	Description of Items in Figure 54
1	Pulse repetition interval (PRI) of signal 1. PRI is measured in time units. PRI is equivalent to $1/\text{PRF}$, where PRF is the pulse repetition frequency.

Item	Description of Items in Figure 54
2	Pulse repetition interval (PRI) of signal 2.
3	Pulse width (τ) of signal 1. Pulse width is also referred to as τ (tau)
4	Pulse width τ of signal 2.
5	Signal delay of signal 2. Notice that the signal delay is zero for signal 1.
6	Gate trigger input for Option 105. The trigger input coincides with signal 1.

Use the guidelines in Table 3 when using Option 105 to view a pulsed RF signal. These are only guidelines, and the spectrum analyzer settings can be changed if necessary.

Table 3 **Determining Spectrum Analyzer Settings for Viewing a Pulsed RF Signal**

Spectrum Analyzer Function	Spectrum Analyzer Setting	Comments
Sweep Time	Set the sweep time to be 401 times greater than the pulse repetition interval (PRI): Sweep time > 401 × PRI	Because the gate must be on at least once per trace point, the sweep time has to be set to the pulse repetition interval times for every point of the trace. (Each trace has 401 points.)
Gate Delay	The gate delay is equal to the signal delay plus half of the pulse width: Gate Delay = Signal Delay + $\tau/2$	The gate delay must be set so that the gating captures the pulse. If the gate delay is too short or too long, the gating can miss the pulse or include resolution bandwidth transient responses.
Gate Length	The gate length is equal to one-fourth the pulse width: Gate Length = $\tau/4$	If the gate length is too long, the signal display can include transients caused by the spectrum analyzer filters.

Table 3 **Determining Spectrum Analyzer Settings for Viewing a Pulsed RF Signal**

Spectrum Analyzer Function	Spectrum Analyzer Setting	Comments
Video Bandwidth	Set the video bandwidth to a value greater than 1 divided by the gate length: $\text{Video Bandwidth} > \frac{1}{\text{gate length}}$	The video bandwidth must be wide enough so that the rise times of the video bandwidth do not attenuate the signal.
Resolution Bandwidth	Set the resolution bandwidth to a value greater than 2 divided by the gate delay minus the signal delay: $\text{Resolution Bandwidth} > \frac{2}{\text{Gate Delay} - \text{Signal Delay}}$	The resolution bandwidth must be wide enough so that the charging time for the resolution bandwidth filters is less than the pulse width of the signal.

Example of a Time-Gated Pulsed RF Signal

The measurement procedures in this section explain how to use the time gate capability without the convenience of the Gate Utility functions. The Gate Utility provides the user with simultaneous displays of the frequency and time domain to assist in setting up and manipulating the time gate. An oscilloscope is not needed when using the Gate Utility.

NOTE:

This example only applies to using Option 105 with a pulsed RF signal.

The following example demonstrates the rules for setting up a time-gated measurement. In this example, we are using two signal generators to generate two signals at the same frequency (50 MHz). The pulse generators “space” (interleave) the signals in time as well as pulse modulate the signals.

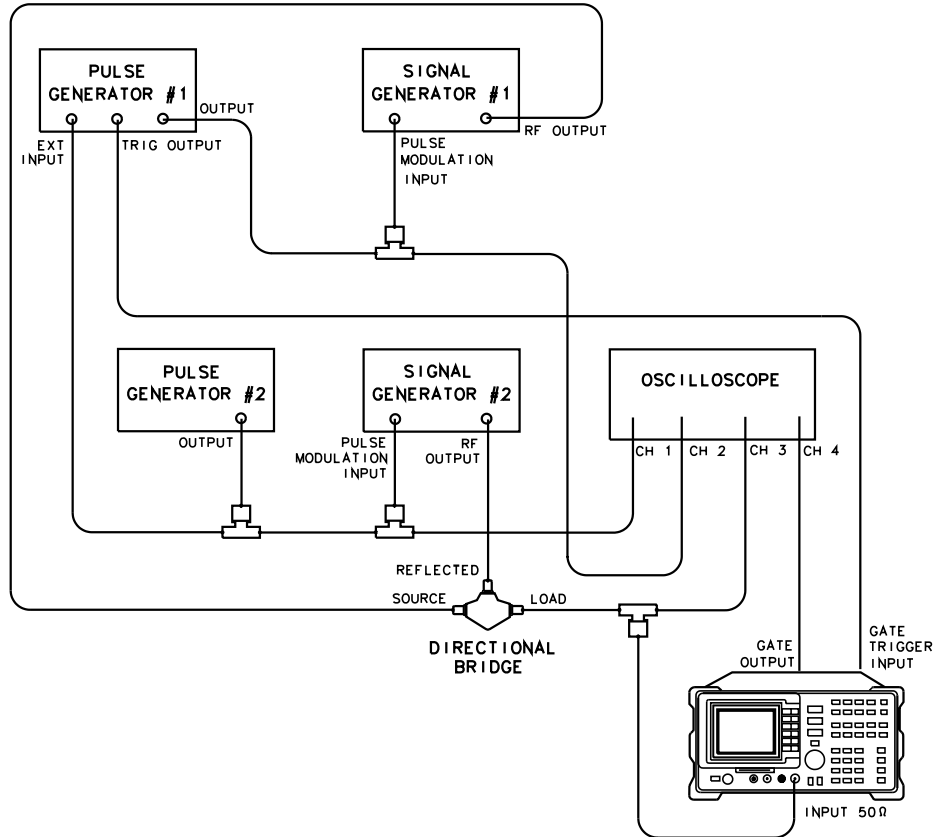

Figure 55 Test Setup for Option 105

NOTE: Be sure that the input impedance for the oscilloscope channels is set to 1 MΩ.

Table 4 Pulse Generator Test Setup Settings

Setting	Pulse Generator #1	Pulse Generator #2
Period	280 μs	280 μs
Width	50 μs	50 μs
Trigger	Positive edge of square wave	Not applicable
Voltage (peak to peak)	5 V	5 V
Trigger delay	85 μs	None

Table 5 Signal Generator Test Setup Settings

Setting	Signal Generator 1	Signal Generator 2
Frequency	50 MHz	50 MHz
Amplitude	-1 dBm	-10 dBm
Pulse Modulation	On	On

- 1 Set the center frequency of the spectrum analyzer to the frequency of the modulated signal. Decrease the frequency span of the spectrum analyzer. If necessary, adjust the reference level of the spectrum analyzer so that the peak signal is displayed near the top graticule.

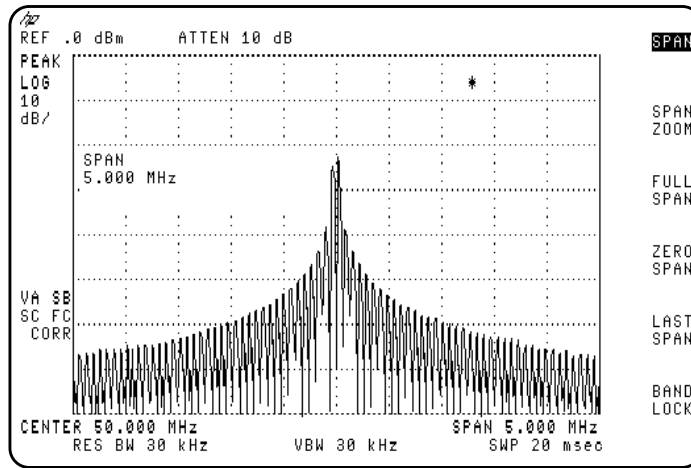

Figure 56 Setting the Center Frequency, Span and Reference Level

NOTE:

The Gate Utility can be used to simplify the following steps.

- 2 Set the sweep time to be 401 times greater than the pulse repetition interval. For this example, the pulse repetition interval is 280 μ s, so the sweep time is set to greater than 401 times 280 μ s, or 0.112 s. For this example, we are using a sweep time of 120 milliseconds. Press **(SWEEP)**, 120 **(ms)**.

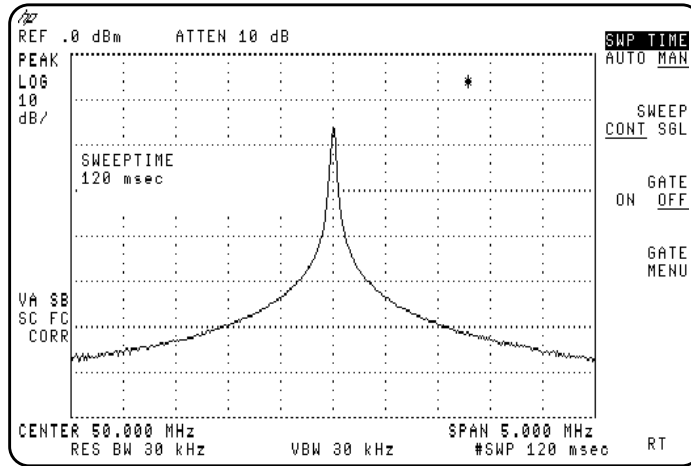

Figure 57 Setting the Sweep Time

- 3 Turn the gate on by pressing **SWEEP**, **GATE ON OFF** (so that ON is underlined).

Using an oscilloscope makes it easier to ensure that the gate occurs during the pulsed RF signal. With GATE OUTPUT connected to the oscilloscope, you can adjust the gate length and gate delay so that the gate occurs near the end of the pulse. See Figure 58 on page 132.

Making Measurements in Spectrum Analyzer Mode
Time-Gating (Option 105 only)

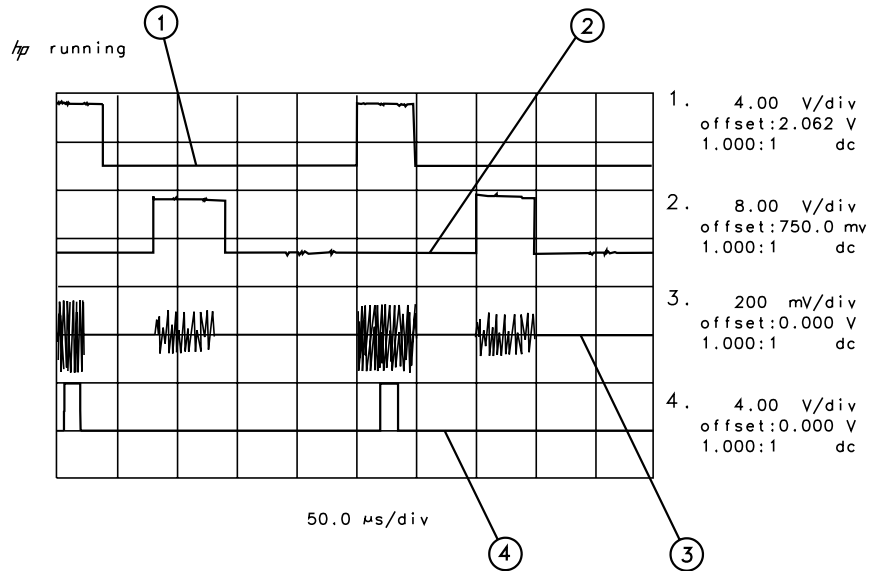

Figure 58 Setting the Gate Delay and Gate Length Using an Oscilloscope

Item	Description of Items in Figure 58
1	Output from pulse generator 1.
2	Output from pulse generator 2.
3	Pulsed RF signal input to the spectrum analyzer.
4	Gate output from Option 105. Notice that the gate output is directly below signal 1.

If you do not have an oscilloscope, it is very important to use the guidelines for determining gate length and gate delay. See “Setting the Gate Delay and Gate Length Properly” following this section.

- 4 The gate delay must be equal to the signal delay plus the pulse width (τ) divided by 2. For the first signal, there is no signal delay, so the gate delay needs to be set to $50 \mu\text{s}/2$, or $25 \mu\text{s}$. Press **(SWEEP)**, **Gate Control**, **GATE DELAY** 25 **(μS)**.
- 5 Set the gate length to a value equal to the pulse width (τ) divided by 4. For this example, the gate length is set to $50 \mu\text{s}/4$, or $13 \mu\text{s}$. Press **GATE LENGTH**, 13 **(μS)**.

- 6 Set the resolution bandwidth to a value that is greater than 2 divided by the gate delay minus the signal delay. For this signal 1, there is no signal delay, so the resolution bandwidth is set greater than $2/25 \mu\text{s}$, or greater than 80 kHz. Press **(BW)**, 100 **(kHz)**.
- 7 Set the video bandwidth to a value that is greater than 1 divided by the gate length. For this example, the video bandwidth must be greater than $1/13 \mu\text{s}$, or 80 kHz. Press **(BW)**, **VID BW AUTO MAN**, 100 **(kHz)**.

See Figure 59. The spectrum analyzer displays only signal 1, not both signal 1 and signal 2.

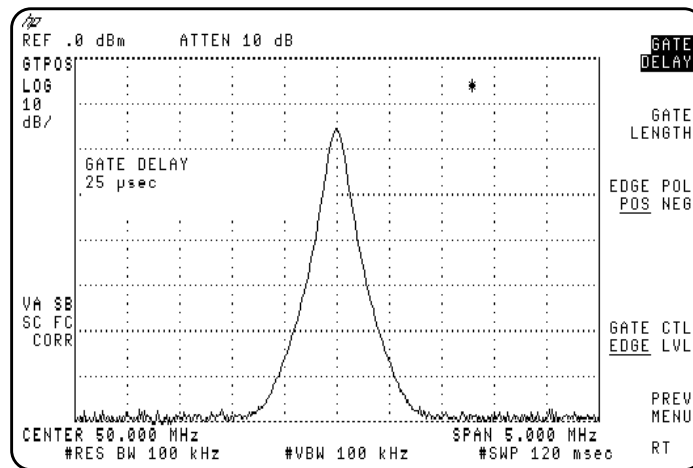

Figure 59 Using Time-Gating to View Signal 1

- 8 To compare signal 1 to signal 2, we first place signal 1 (trace A) in the view mode. Press **(TRACE)**, **VIEW A**, **TRACE A B C** (so that B is underlined), **CLEAR WRITE B**.
- 9 To view the second signal, change the gate delay so that the gate output is under the second signal. Since the second signal had a signal delay of approximately $85 \mu\text{s}$, we set the gate delay to $85 \mu\text{s}$ plus the pulse width/2, or $110 \mu\text{s}$. Press **(SWEEP)**, **Gate Control**, **GATE DELAY** 110 **(μs)** to set the gate delay to $110 \mu\text{s}$. Using an oscilloscope can be helpful in placing the gate output during the pulsed signal. See Figure 60 on page 134.

Making Measurements in Spectrum Analyzer Mode
Time-Gating (Option 105 only)

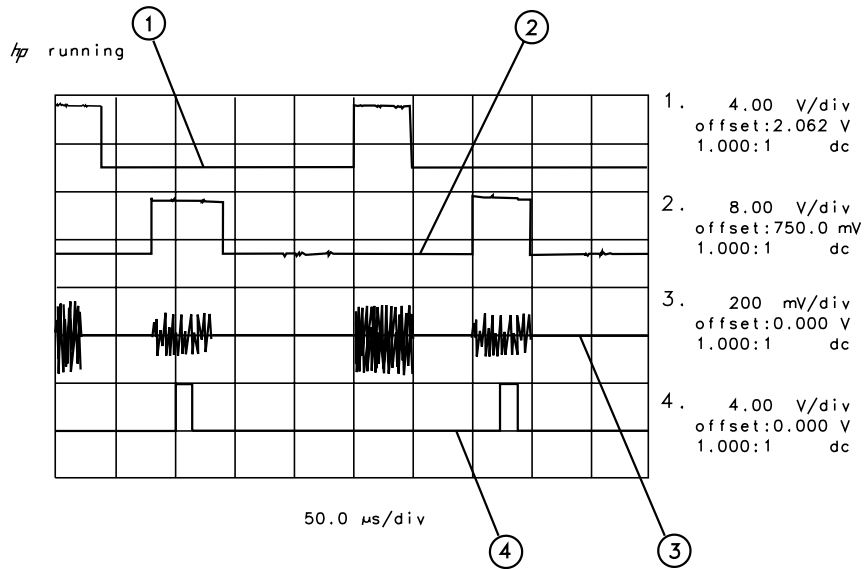

Figure 60 Placing the Gate Output During the Second Signal

Item	Description of Items in Figure 60
1	Output from pulse generator 1.
2	Output from pulse generator 2.
3	Pulsed RF signal input to the spectrum analyzer.
4	Gate output from Option 105. Notice that the gate output is directly below signal 2.

10 Set the resolution bandwidth to a value that is greater than 2 divided by the gate delay ($110 \mu\text{s}$) minus the signal delay ($85 \mu\text{s}$). The resolution bandwidth should be set to greater than 2 divided by $25 \mu\text{s}$, or greater than 80 kHz. Press **(BW)**, **RES BW**, 100 **(kHz)**.

11 Since the gate length was not changed, the video bandwidth is still 100 kHz.

Figure 61 on page 135 shows the first pulsed RF signal (contained in trace A), and the second pulsed RF signal (contained in trace B).

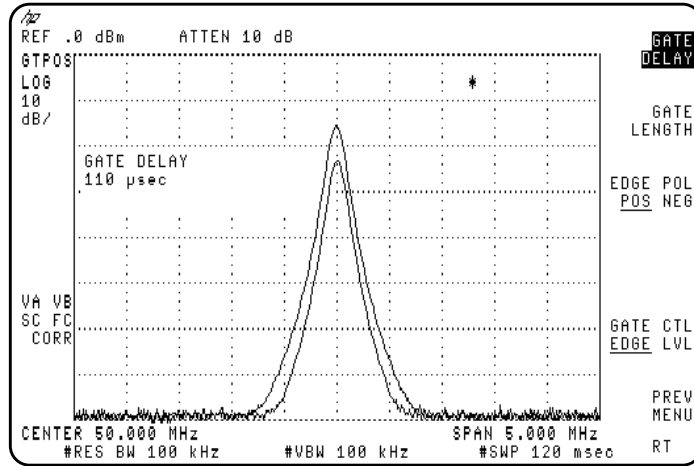

Figure 61 Viewing Both Signals with Time-Gating

Setting the Gate Delay and Gate Length Properly, When NOT Using the Gate Utility

If the gate delay and gate length are not set properly, you may not be viewing an accurate representation of a signal. For example, If the gate does not occur during the RF pulsed signal, the amplitude of the signal displayed on the spectrum analyzer is lower than the actual signal. See Figure 62.

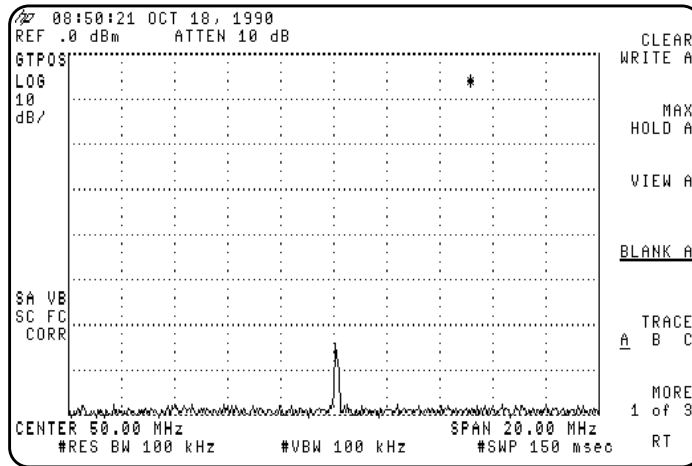

Figure 62 Gate Not Occurring During the Pulse

The time gate is implemented after the resolution bandwidth filtering and before the video filtering. The displayed signal is a result of the decay time for the resolution bandwidth filters and is not an accurate representation of the input signal.

If the gate occurs at the beginning of the RF pulse signal or at the end of the RF pulse signal, the signal displayed on the spectrum analyzer can be attenuated or contain transient signals caused by the spectrum analyzer. See Figure 63 on page 137. If this happens, decrease the gate length and change the gate delay to place the gate output during the signal.

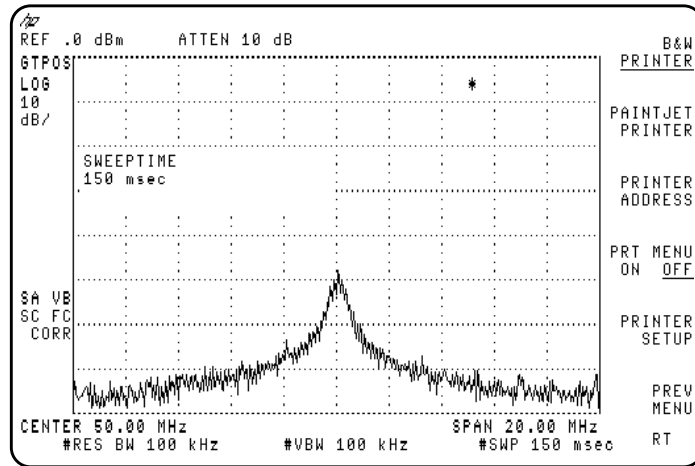

Figure 63 Gate is Occurring at the Beginning of the Pulse

In Figure 63, the peak amplitude has not been reached, and the transient response of the resolution bandwidth filters adds noise.

Table 6 and Table 7 on page 139 provide the recommended initial spectrum analyzer settings when measuring a signal without signal delay.

NOTE:

Refer to the guidelines in Table 3, “Determining Spectrum Analyzer Settings for Viewing a Pulsed RF Signal,” on page 127 when measuring a signal with signal delay.

To use Table 6 and Table 7:

- Determine the pulse width of the signal you want to measure, then use Table 6 to determine the gate delay, resolution bandwidth, gate length, and video bandwidth spectrum analyzer settings.
- Determine the pulse repetition rate of the signal, then use Table 7 to determine the spectrum analyzer sweep-time setting.

NOTE:

The peak detection mode is recommended for making gated measurements.

Table 6 Gate Delay, Resolution Bandwidth, Gate Length, and Video Bandwidth Settings

Pulse width (τ)	Gate Delay	Resolution Bandwidth	Gate Length	Video Bandwidth
10 μ s	5 μ s	1 MHz	3 μ s	1 MHz
50 μ s	25 μ s	100 kHz	13 μ s	100 kHz
63.5 μ s	32 μ s	100 kHz	16 μ s	100kHz
100 μ s	50 μ s	100 kHz	25 μ s	100kHz
500 μ s	250 μ s	10 kHz	125 μ s	10kHz
1 ms	500 μ s	10 kHz	250 μ s	10 kHz
5 ms	2.5 ms	1 kHz	1.25 ms	1 kHz
10 ms	5 ms	1 kHz	2.5 ms	1 kHz
16.6 ms	8.3 ms	1 kHz	4 ms	1 kHz
33 ms	16.5 ms	1 kHz	8 ms	1 kHz
50 ms	25 ms	1 kHz	13 ms	1 kHz
100 ms	50 ms	1 kHz	25 ms	1 kHz
\geq 130 ms	65 ms	1 kHz	33 ms	1 kHz

When using the short gate delays, you may notice the gate delay time jitter by $\pm 1 \mu$ s. This jitter is due to the spectrum analyzer 1 MHz gate clock, and it does not indicate a problem.

Table 7 Sweep Time Settings

Pulse Repetition Interval (PRI)	Pulse Repetition Frequency (PRF)	Sweep Time (minimum)
≤50 μs	≥20 kHz	21 ms
100 μs	10 kHz	41 ms
500 μs	2 kHz	201 ms
1 ms	1 kHz	401 ms
5 ms	200 Hz	2.01 s
10 ms	100 Hz	4.01 s
16.7 ms	60 Hz	6.7 s
33.3 ms	30 Hz	13.4 s
50 ms	20 Hz	20.1 s
100 ms	10 Hz	40.1 s
200 ms	5 Hz	80.2 s
249 ms	4 Hz	100 s
>249 ms	Use the MAX HOLD trace function and take several measurement sweeps.	

Using the Self-Calibration Routines with Option 105

The spectrum analyzer self-calibration routines (initiated by pressing **CAL AMPTD** or **CAL FREQ & AMPTD**) should be performed prior to using the Option 105 functions. Use the following procedure to perform the self-calibration routines and to check the results of the self-calibration routines.

NOTE:

Be sure that the GATE TRIGGER INPUT connector (on the spectrum analyzer rear panel) is not connected to anything while performing the spectrum analyzer self-calibration routines.

- 1 Remove the cable from the GATE TRIGGER INPUT connector.
- 2 Connect the CAL OUT connector to the spectrum analyzer input connector with the calibration cable.
- 3 Press **(CAL)**. Press either **CAL FREQ & AMPTD** (to perform the frequency and amplitude self-calibration routines) or **CAL AMPTD** (to perform the amplitude self-calibration routine).
- 4 When the self-calibration routines have successfully completed, press **CAL STORE**.
- 5 Press **(CAL)**, **More 1 of 4**, **More 2 of 4**, **Service Diag**, **DISPLAY CAL DATA**, then **NEXT PAGE**.
- 6 Verify that the number displayed for GATE, in the lower left corner, is between 0.98 and 1.0. See Figure 64.

```

                                TUNING
CAL      300000000  Sweepsens <10M 0.000185303
ZERO     211990016  Sweepsens Wide 0.000002030
FAST     56503057   Main Coil Sens 0.038835200
MED      1114621728 FM Coilsens Er 0.958118558
SLOW     22348669   Wide Disc Err  2.590917587
PkOfst   28        Hdsc sweepsens 0.000502140
TCXO     -98       EYO Δ slope    5E-10
Last Cal Freq 18:18:33 MAR 04, 1992
Last Cal Amp  18:26:17 MAR 04, 1992

TRACKING GEN  FM DEMODULATION
AOFST        3051  ZERO          0
XOFST        3095  SLOPE        16893
DCORR       -22372 Narrow BW   1756
ASLOP 0.617283940 Wide BW    1751
FSLOP 0.000000168
XSLOP 0.307900012
GATE 0.999294639

```

Figure 64 Self-Calibration Data Results

If the number is not between 0.98 and 1.0, check that the GATE TRIGGER INPUT connector is not connected to anything, then repeat the previous steps of this procedure.

- 7 Press **PRESET**.

Performing a Functional Check of Option 105

To check that the time-gated spectrum analyzer capability is operational, perform the following steps:

- 1 Connect the rear panel HIGH SWEEP IN/OUT connector to the GATE TRIGGER INPUT connector with a short BNC calibration cable. See Figure 65.

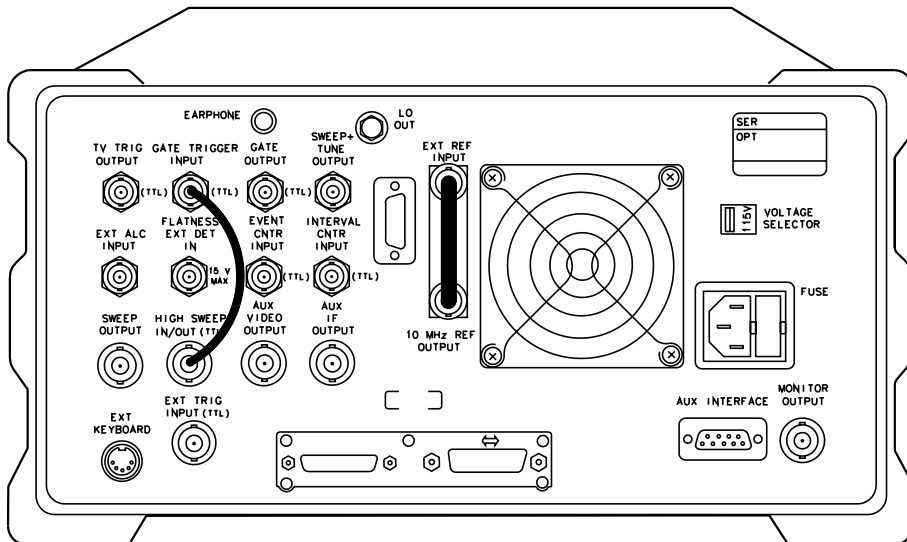

Figure 65 Rear Panel Connections for Option 105

- 2 Press **PRESET**, **FREQUENCY**, 0 Hz, **SPAN (SPAN)**, **ZERO SPAN**, **SWEEP**, 200 ms, **Gate Control**, **GATE DELAY**, 60 ms, **GATE LENGTH**, 60 ms.

The **GATE CTL EDGE LVL** softkey should have **EDGE** underlined, and **EDGE POL POS NEG** should have **POS** underlined.

- 3 Press **Previous Menu**, **GATE ON OFF** (so that **ON** is underlined). See Figure 66 on page 143.

NOTE:

This procedure offers a qualitative functional check only. Due to several factors, the accuracy of the marker readout of the gate delay and gate length can vary by several milliseconds. For more information about gate timing, see the Characteristics in specifications and characteristics in your calibration guide for your spectrum analyzer.

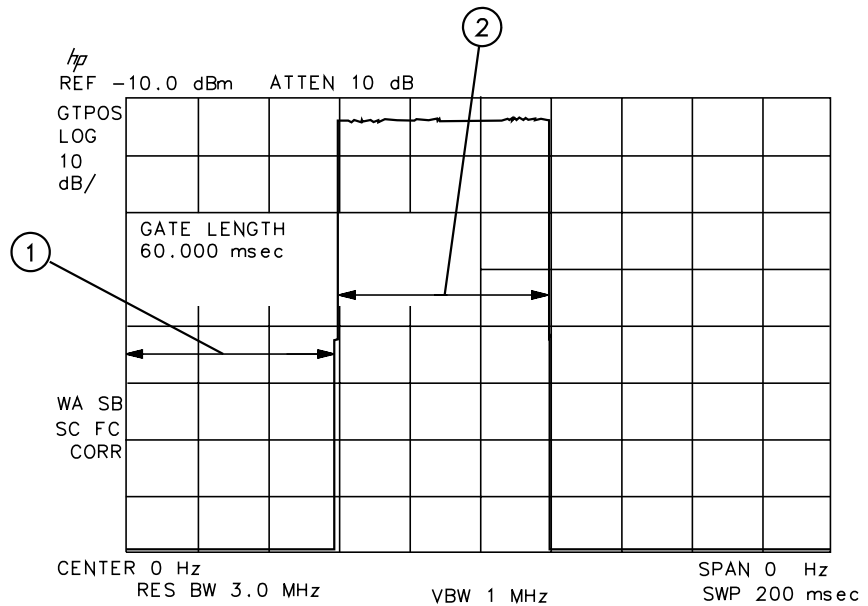

Figure 66 Gate On

Item	Description of Items in Figure 66
1	Represents the gate delay. The gate is off during the gate delay.
2	Represents the gate length. The gate is on, and the HI SWEEP IN/OUT signal is displayed.

- 4 To check the gate control function, press (SWEEP), Gate Control, GATE CTL EDGE LVL so that LVL (level) is underlined. See Figure 67 on page 144.

Making Measurements in Spectrum Analyzer Mode Time-Gating (Option 105 only)

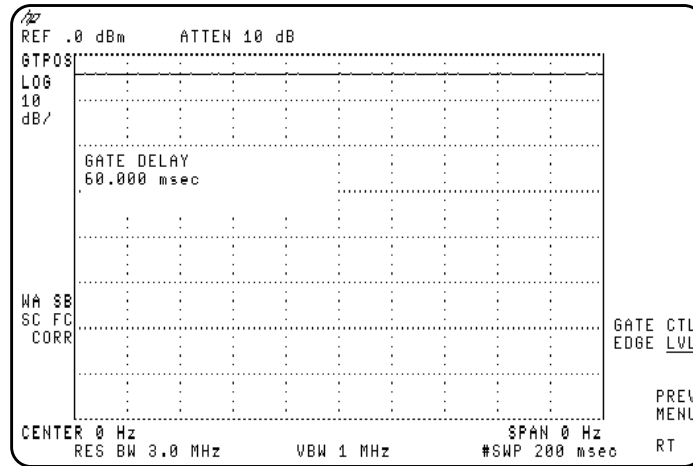

Figure 67 Using the Level Gate Control

When the **GATE CTL EDGE LVL** softkey function is set to edge, triggering occurs at the edge of the trigger input. When the **GATE CTL EDGE LVL** softkey function is set to level, the gate is on whenever the trigger input is high. Because the trigger input for this example is the HI SWEEP IN/OUT signal, and HI SWEEP IN/OUT signal is high (+5 V) during every sweep, the level of the signal on screen is high.

Notice that the **GATE DELAY**, **GATE TIME**, and **EDGE POL NEG POS** softkeys are blanked when the gate control is set to level. When the gate control is set to level (LVL), the functions of gate delay, gate length, and edge trigger polarity no longer apply.

If You Have a Problem

If You Have a Problem

What You'll Find In This Chapter

This chapter helps you troubleshoot any problems found while operating the GSM Multiband Transmitter Measurement Personality, including any hardware or options installed with the personality to make it function. If the problem is related to the spectrum analyzer and not the GSM Multiband Transmitter Measurement Personality, consult the spectrum analyzer documentation.

This chapter uses displayed error messages as the foundation for troubleshooting problems with the GSM Multiband Transmitter Measurement Personality. It is likely that an error message is the first thing you see following a failure. However, a procedure is also provided for problems not reported by an error message. The messages are listed in alphabetical order, followed by a brief explanation.

- 1 First, follow the procedure listed in “Before Troubleshooting.” Most issues involving setup and common errors are discussed there.
- 2 Second, if an error message is displayed, locate the message in “Error Messages” in this chapter and follow the directions given for that message.
- 3 If required, contact your nearest HP Sales and Service Office listed at the end of this chapter.

Before Troubleshooting

If an error message appears, or if you suspect a problem, check the system setup first. Make sure the GSM Multiband Transmitter Measurement Personality settings match the signal type under test.

Check the following common errors:

- Testing a mobile station when the personality is configured for a base station, or vice versa. This is set by **TX MS BS** in the physical channel menu.
- Tuning to the wrong carrier channel or timeslot number. These are set by **ARFCN** and **TIMESLOT NUMBER** in the physical channel menu.
- The external attenuation being set incorrectly. This is set by **EXT ATTEN** in the configuration menu.
- No frame trigger being supplied to the rear panel GATE TRIGGER INPUT when required by a measurement.
- The GATE OUTPUT not being connected to the EXT TRIG INPUT.

If the Spectrum Analyzer does not appear to respond to key presses

During phase and frequency error measurements this may occur when there is no frame trigger supplied or if the frame trigger is configured incorrectly. Pressing **(PRESET)** returns the spectrum analyzer to the default state.

If the GSM Multiband Transmitter Measurement Personality does not make a measurement

If you press one of the measurement functions and the personality does not make the measurement, it could be caused by one of the following:

- The channel number is not correct.
Make sure that the channel number corresponds to the transmitted carrier frequency. **AUTO ARFCN** and **AUTO ARFCN & TN** in the physical channel menu can be used to automatically find the carrier in the transmit band with the highest signal level.
- The external trigger signal is missing.
Make sure that a repetitive external trigger is input to the spectrum analyzer, when required. External triggering is used for channel power, power versus time, RF spectrum due to modulation and phase and frequency error measurements.
- The timeslot number is wrong.
Make sure that the timeslot number corresponds to a carrier pulse. **AUTO TN**, **P vs T FRAME**, **TRIG DELAY** and **AUTO ARFCN & TN** can be used to select the correct timeslot number.
- While in Phase and Frequency Error Measurement mode a DLP parameter is highlighted.
To restart the measurement, press **(ENTER)** or **Previous Menu**.

If the test results are not what you expected

If the test results are incorrect or not what you expected, it could be caused by one of the following conditions:

- The external trigger settings are not correct.
Make sure that the correct trigger source, period, delay, and polarity have been selected.
- The personality is configured for the wrong transmitter format.
Make sure that BS is underlined in the **TX BS MS** softkey (in the physical channel menu), if a base station is being tested. Likewise, make sure that MS is underlined in the **TX BS MS** softkey, if a mobile station is being tested.

- The external attenuation value is incorrect.
Make sure that the **EXT ATTEN**, in the configuration menu, has been set correctly. A symptom of this problem is incorrect power measurement results, and **NO CARRIER** error messages.
- The total power setting is incorrect.
Make sure that **TOTL PWR SGL MULT**, in the configuration menu, has been set correctly. If only one carrier is incident to the spectrum analyzer, make sure SGL is underlined. If multiple carriers are incident, make sure MULT is underlined and the value for the TOTL PWR function is equal to the total power for all the carriers. Use **MONITOR TX BAND** to set the value automatically.
- The Slow Frequency Hopping (SFH) is incorrect.
Make sure that **SFH ON OFF** is set to OFF, unless the signal being measured is hopping.
- The self-calibration routines need to be performed as described in chapter 1.
Perform the self-calibration routines periodically to make accurate measurements. When you perform the spectrum analyzer self-calibration routines, make sure that nothing is connected to the GATE TRIGGER INPUT connector on the spectrum analyzer rear panel. If there is anything connected to the GATE TRIGGER INPUT connector during the self-calibration routines, it can cause incorrect calibration data. A symptom of this problem is that the time-gated channel power measurement trace results are displayed too far up on the spectrum analyzer display (even above the top graticule).
If the error message **CAL: DD DAC Failed** appears on the screen, then the spectrum analyzer attempted to run an amplitude self-calibration but failed. In this case, make sure the calibration reference signal is connected to the front panel input connector and run the calibration again. If it still fails, the option 151 assembly may be faulty. Contact your nearest HP sales and service office.
- Excess frequency drift is interrupting the measurement.
The spectrum analyzer center frequency has not yet stabilized to internal operating temperature. Wait a few minutes after turning on the spectrum analyzer until the **OVEN COLD** message disappears before beginning phase and frequency error measurements.

If You Have a Problem
Before Troubleshooting

- Additional carriers are interfering with the measurement.
For phase and frequency error measurements, carriers should be at least 2 MHz apart, if problems persist make sure only one carrier is incident to the spectrum analyzer. For other measurements, carriers should be at least 1 MHz apart.
- Noise on the external frequency reference is interfering with the phase and frequency error measurements.
Poor sideband noise or sideband spurs on the external reference may worsen the measurement results. Try using the spectrum analyzer rear panel option 004, Precision Reference Frequency, to examine differences in the noise level.
- Vibration effects are interfering with the measurement.
The frequency error measurement may show some sensitivity to vibration. Mount the spectrum analyzer on a steady base and avoid knocking or moving the spectrum analyzer while measurements are in progress.
- Frequency has not stabilized after a large frequency shift.
The frequency error measurement may show an error after a large frequency shift. Repeating the measurement should correct this problem.
- **FREQ ERR OFFSET** value is not sufficient to compensate for frequency error.
The **FREQ ERR OFFSET** function allows a known frequency error to be used as an offset in the frequency error measurement. This offset can be made equal to the average frequency error, which for best effect should be determined over a minimum of 15 bursts. At the end of the set number of bursts, the value displayed on the analyzer is the average frequency error for the system. Assign this value to the **FREQ ERR OFFSET** function and rerun the frequency error measurement. The displayed average frequency error should settle close to 0 Hz after about 10 bursts.

Error Messages

All error messages are listed alphabetically by the first word in the message.

AMPLITUDE > 1 dB OFF!

This message indicates that the CW source's test signal amplitude measured greater than 1 dB from the intended value during the Intermodulation Attenuation Measurement procedure.

To solve this problem:

- Ensure that the requested CW signal frequency and level are correct.

CAL: DD DAC Failed

This message indicates that the spectrum analyzer attempted to run an amplitude self-calibration but failed.

To solve this problem:

- Make sure the calibration reference signal is connected to the front panel input connector.
- If the calibration reference signal is correct, the option 151 assembly may be faulty. Contact your nearest HP sales and service office.

CARRIER PRESENT, CHECK SETUP!

This message indicates that the maximum signal level measured during the Intermodulation Attenuation RX Band measurement is greater than expected.

To solve this problem:

- A bandpass filter (BPF) is required in this measurement setup configuration. Refer to 'Intermodulation Attenuation Measurements' on page 72 to verify the setup.
- Ensure there is no carrier being generated which lies within the test frequency band.

CARRIER PRESENT, TEST STOPPED!

This message indicates that the maximum signal level measured is greater than the expected value. The measurement is stopped because it is not reasonable to continue when a carrier is present.

To solve this problem:

- A bandpass filter (BPF) may be required in this measurement setup configuration. Refer to the measurement procedure to verify the setup.
- Ensure there is no carrier being generated which lies within the test frequency band.

CHECK NOISE FLOOR

This message indicates that the spurious signal was measured with spectrum analyzer settings at conditions in which its sensitivity specification exceeded or was within 6 dB of the spurious specification.

To solve this problem:

- Examine the spurious signal in more detail using the **Inspect Spur** key.
- Remove the input signal, if the spur remains, it is caused by noise in the test equipment.

DD DSP FAIL

This message indicates that either the option 151 GSM digital demodulator is faulty or that the option 163 GSM DSP firmware is missing or faulty.

To solve this problem:

- If option 151 is installed in the spectrum analyzer it may have failed. See the documentation for your spectrum analyzer for more information about returning the spectrum analyzer for repair.
- If option 151 is installed in the spectrum analyzer, option 163 is required. If option 163 is not installed; contact your local HP Sales and Service Office for more information.
- If option 163 is installed in the spectrum analyzer it may be faulty. See the documentation for your spectrum analyzer for more information about returning the spectrum analyzer for repair.

EXT PRECISION FREQ REFERENCE REQUIRED

This indicates that the spectrum analyzer does not have option 004, the precision frequency reference, installed. If the spectrum analyzer does not have option 004 installed, you must use an external precision frequency reference to make accurate measurements with the GSM Multiband Transmitter Measurement Personality.

To use an external precision frequency reference:

- Disconnect the connector from the 10 MHz REF OUTPUT and EXT REF IN connectors on the rear panel. Connect the 10 MHz signal from a precision external frequency reference to the EXT REF IN connector. Note that the message will still be present when an external 10 MHz reference is correctly connected.

EXTERNAL TRIG REQUIRED

This message indicates that the measurement requested requires an external trigger signal.

To solve this problem:

- Connect a frame trigger signal to the rear panel EXT TRIG INPUT (TTL) port.
- The FRAME TRIG OUTPUT (TTL) port can be used to supply the frame trigger signal, however, this signal is likely to drift compared with the device under test.

FAST ADC REQUIRED: (Opt 101 or Opt 151)

This indicates that neither options 101 or 151 have been installed in the spectrum analyzer. Option 101 is the fast time-domain sweep assembly, and option 151 is the GSM digital demodulator assembly. Your spectrum analyzer must have fast ADC capability for the power versus time measurements on a mobile station when used with the HP 85727A GSM Multiband Transmitter Measurement Personality.

The fast ADC function required for the phase and frequency error measurement has been added to the option 151 assembly. The option 101 fast time-domain sweep assembly is *not* recommended to be installed with option 151. Option 151 replaces option 101 functions in the spectrum analyzer for GSM Multiband Transmitter Measurement Personality.

To solve this problem:

- If option 101 or 151 is installed in the spectrum analyzer, that option may have failed. See the documentation for your spectrum analyzer for more information about returning the spectrum analyzer for repair.
- If option 101 or 151 is not installed in the spectrum analyzer, either option can be installed; contact your local HP Sales and Service Office for more information.

FREQUENCY > 0.1 MHz OFF!

This message indicates that the CW source's test signal frequency measured greater than 0.1 MHz from the intended value during the Intermodulation Attenuation Measurement procedure.

To solve this problem:

- Ensure that the requested CW signal frequency and level are correct.

GATE CARD REQUIRED: (Opt 105)

This indicates that the spectrum analyzer does not have option 105, the time-gated spectrum analysis card, installed. Option 105 must be installed to make most GSM measurements.

To solve this problem:

- If option 105 is installed, it may have failed. See the documentation for your spectrum analyzer for more information about returning the spectrum analyzer for repair.
- If option 105 is not installed in the spectrum analyzer, it can be installed; contact your local HP Sales and Service Office for more information.

GSM Phase Frequency firmware required: (opt 163)

This indicates that the spectrum analyzer does not have option 163, the GSM firmware installed in the option 151 digital demodulator assembly.

To solve this problem:

- If option 163 is installed in the spectrum analyzer, it may have failed. See the documentation for your spectrum analyzer for more information about returning the spectrum analyzer for repair.
- If option 163 is not installed in the spectrum analyzer, it can be installed; contact your local HP sales and service office for more information.

INSERT HP 85727A MEMORY CARD & TRY AGAIN

This message indicates that the memory card containing the GSM Multiband Transmitter Measurement Personality was not found in the card reader.

To solve this problem:

- Insert the card so that the measurement you have selected can be loaded into the spectrum analyzer's memory.

INVALID SYMTAB ENTRY: SYMTAB OVERFLOW

This indicates that there was not enough available memory in the spectrum analyzer to hold the HP 85727A GSM Multiband Transmitter Measurement Personality.

To solve this problem:

- Press **(CONFIG)**, **More 1 of 3**, **SHOW OPTIONS** and check the firmware version of your spectrum analyzer.

If the version is earlier than 931217, then obtain the latest spectrum analyzer firmware from your nearest HP Customer Sales and Service Office. Earlier firmware dates were given in a different format with the word REV preceding the day, month, and year separated by periods.

- If your spectrum analyzer firmware is 931217 or later, then there is insufficient available memory. You must delete the other programs in the spectrum analyzer memory as follows:
 - 1 Press **(PRESET)**.
 - 2 Press **(CONFIG)**, **More 1 of 3**, **Dispose User Mem**, **ERASE DLP MEM**, **ERASE DLP MEM**, **(PRESET)**.
 - 3 Reload the GSM Multiband Transmitter Measurement Personality using the procedure in 'Loading the HP 85727A GSM Multiband Transmitter Measurement Personality' on page 21.

MIDAMBLE BAD Error bits - Wrong Color Code?

This message indicates that the phase and frequency error measurement has detected a midamble bit sequence which does not match the selected color code value.

To solve this problem:

- If the color code selection is set to manual (**COLOR AUTO MAN**, MAN underlined) select the correct color code pattern for the signal being measured. Alternatively select AUTO underlined, for automatic detection of the color code pattern.
- If the color code selection is set to automatic (**COLOR AUTO MAN**, AUTO underlined) the measured signal does not match any recognized color code pattern. Check the DATA BITS screen.
- Set **SYNC MID AMPL** to AMPL underlined, so that the spectrum analyzer uses the rising edge of the burst for synchronization.

NEWER FIRMWARE REQUIRED: REV 931217 OR LATER

This message indicates that the spectrum analyzer firmware must be updated before the GSM Multiband Transmitter Measurement Personality can be used.

Press (**CONFIG**), **More 1 of 3**, **SHOW OPTIONS** to view the firmware version of your spectrum analyzer. Earlier firmware dates were given in a different format with the word REV preceding the day, month, and year separated by periods.

To solve this problem:

- Contact your local HP Sales and Service Office for more information about updating the firmware in your spectrum analyzer.

Newer opt 163 firmware required: rev 931217 or later

This message indicates that newer option 163 firmware is required for the HP 85727A GSM Multiband Transmitter Measurement Personality.

To solve this problem:

- Contact your local HP sales and service office for information about obtaining the latest option 163 ROMs.

NO CARRIER!

This message indicates that the maximum signal level measured is less than the expected value for valid carrier power.

To solve this problem:

- Verify that the correct channel number (ARFCN) and timeslot number have been selected in the physical channel menu.
- Verify that the external attenuation set in the configuration menu is correct.
- Verify that the signal in the MONITOR TX BAND display is at the correct frequency and at a legitimate level.

NO CARRIER, CHECK SETUP!

This message indicates that the maximum signal level measured during the Intermodulation Attenuation TX Band measurement is less than the expected value for a valid carrier power.

To solve this problem:

- Verify that the correct channel number (ARFCN) and timeslot number have been selected in the physical channel menu.
- Verify that the external attenuation set in the configuration menu is correct.
- Verify that the signal in the MONITOR TX BAND display is at the correct frequency and at a legitimate level.

NO CARRIER LEVEL <-20 dBm

This message indicates that the maximum signal level measured is less than the expected value for valid carrier power.

To solve this problem:

- Verify that the correct channel number (ARFCN) and timeslot number have been selected in the physical channel menu.
- Verify that the external attenuation set in the configuration menu is correct.
- Verify that the signal in the MONITOR TX BAND display is at the correct frequency and at a legitimate level.

NO CARRIER, TEST STOPPED!

This message indicates that the maximum signal level measured is smaller than the expected value for a valid carrier's power. The measurement is stopped. It is not reasonable to continue the measurement without having a carrier signal with a valid power level because the measurement is in dB relative to the carrier signal.

To solve this problem:

- Verify that the correct channel number (ARFCN) and timeslot number have been selected in the physical channel menu.
- Verify that the external attenuation set in the configuration menu is correct.
- Verify that the signal in the MONITOR TX BAND display is at the correct frequency and at a legitimate level.

NO SPURS

This message indicates that the **INSPECT SPUR** key was pressed, but there were no spurs detected during the Spurious Emissions measurement.

Options 151&163 required for Phase Freq Error

This message indicates that options 151 and 163, are not installed in the spectrum analyzer. Options 151 and 163 are required to make phase and frequency error measurements.

To solve this problem:

- If option 151 and 163 are installed in the spectrum analyzer, they may have failed. See the documentation for your spectrum analyzer for more information about returning the spectrum analyzer for repair.
- If option 151 and 163 are not installed in the spectrum analyzer, they can be installed; contact your local HP sales and service office for more information.

REFERENCE CHANNEL LEVEL <-20 dBm TEST STOPPED!

This message indicates that the maximum signal level measured during the Intra-BSS Intermodulation measurement is less than the expected value for a valid reference channel carrier power.

To solve this problem:

- Verify that the correct channel number (**REF CHANNEL**) has been selected in intermodulation measurement menu.
- Verify that the external attenuation set in the configuration menu is correct.
- Verify that the signal in the MONITOR TX BAND display is at the correct frequency and at a legitimate level.

SIGNAL ERROR

This message indicates that an unexpected burst shape was detected.

To solve this problem:

- Record the value of along with any relevant details then contact your local HP sales and service office for further information.

SIGNAL FREQ ERROR > 10 kHz - Results poor

This message indicates that the detected frequency error was greater than 10 kHz, therefore the reported results may be inaccurate.

To solve this problem:

- Verify that the correct channel number (ARFCN) and timeslot number have been selected in the physical channel menu.
- Verify that the external attenuation set in the configuration menu is correct.
- Verify that the trigger delay set in the configuration menu is correct.
- Examine the signal using **MONITOR TX BAND** in the GSM main menu, and **P vs T FRAME** in the power vs. time menu.

SIGNAL - Idle Burst

This message indicates that during the phase and frequency measurement a trigger was received, but no signal was present. This can be expected during the normal operation of a mobile station.

SIGNAL LEVEL LATE

This message occurs only when the spectrum analyzer is using the midamble section of the burst for synchronization (**SYNC MID AMPL**, MID underlined). This message indicates that the burst amplitude did not rise until after the expected position of the initial bits, which are determined from the detected midamble sequence.

To solve this problem:

- Examine the burst shape using the power versus time menu.
- Set **SYNC MID AMPL** to **AMPL** underlined, so that the spectrum analyzer uses the rising edge of the burst for synchronization.

SIGNAL LEVEL LOW - Decrease REF level

This message indicates that the phase and frequency error assembly is receiving a signal level which is too low to measure accurately.

To solve this problem:

- Verify that the correct channel number (ARFCN) and timeslot number have been selected in the physical channel menu.
- Verify that the external attenuation set in the configuration menu is correct.
- Verify that the trigger delay set in the configuration menu is correct.
- Examine the signal using **MONITOR TX BAND** in the GSM main menu, and **P vs T FRAME** in the power vs. time menu.

SIGNAL LEVEL SHORT

This message occurs only when the spectrum analyzer is using the rising edge of the burst for synchronization (**SYNC MID AMPL**, AMPL underlined). This message indicates that the burst amplitude fell before the expected position of the final bits, which are determined from the detected midamble sequence.

To solve this problem:

- Examine the burst shape using the power versus time menu.
- Set **SYNC MID AMPL** to **AMPL** underlined, so that the spectrum analyzer uses the rising edge of the burst for synchronization.

SIGNAL LEVEL TOO HIGH - Increase REF level

This message indicates that the phase and frequency error assembly is receiving a signal level which is too high to measure accurately.

To solve this problem:

- Press **REPEAT MEAS** to automatically set the reference level to the current signal.
- Verify that the external attenuation set in the configuration menu is correct.
- Verify that the correct channel number (ARFCN) and timeslot number have been selected in the physical channel menu.

SIGNAL NOT DETECTED

This message indicates that the phase and frequency error assembly is not receiving a signal level high enough to measure.

To solve this problem:

- Verify that the correct channel number (ARFCN) and timeslot number have been selected in the physical channel menu.
- Verify that the external attenuation set in the configuration menu is correct.
- Verify that the trigger delay set in the configuration menu is correct.
- Examine the signal using **MONITOR TX BAND** **MONITOR TX BAND** in the GSM main menu, and **P vs T FRAME** in the power vs. time menu.

SIGNAL PHASE ERROR TOO BIG - Results Poor

This message indicates that the detected phase error was greater than 999°, therefore the reported results may be inaccurate.

To solve this problem:

- Verify that the correct channel number (ARFCN) and timeslot number have been selected in the physical channel menu.
- Verify that the external attenuation set in the configuration menu is correct.
- Verify that the trigger delay set in the configuration menu is correct.
- Examine the signal using **MONITOR TX BAND** in the GSM main menu, and **P vs T FRAME** in the power vs. time menu.

SIGNAL SHORT BURST

This message indicates that the amplitude envelope of the burst was shorter than expected.

To solve this problem:

- Examine the burst shape using the power versus time menu.

SIGNAL TOO SHORT

This message indicates that the amplitude envelope of the burst was very much shorter than expected.

To solve this problem:

- Examine the burst shape using the power versus time menu.

Sales and Service Offices

Hewlett-Packard has sales and service offices around the world to provide support for your spectrum analyzer and the HP 85727A GSM Multiband Transmitter Measurement Personality. To obtain servicing information or to order replacement parts, contact any sales office listed in Table 8, “Hewlett-Packard Sales and Service Offices,” on page 164.

In any correspondence or telephone conversations, refer to the spectrum analyzer by its model number and its firmware date code. Use the following steps to determine the firmware date code:

- 1 Press **CONFIG** on the spectrum analyzer front panel.
- 2 Press **MORE 1 OF 3**.
- 3 Press **ANALYZER ADDRESS**.
- 4 Key in the spectrum analyzer address, 18, then press **ENTER**.
- 5 Read the firmware date code on the display.

Refer to the measurements personality by the version number listed on the label of the GSM Multiband Transmitter Measurement Personality. You can also display the version number on the display by following the procedure below:

- 1 After loading the GSM Multiband Transmitter Measurement Personality into the spectrum analyzer’s user memory, press **GSM ANALYZER**, **Config**.
- 2 Press **More 1 of 3**, **More 2 of 3**, **GSM REC VER**.
- 3 Read the displayed version of the GSM Multiband Transmitter Measurement Personality you are using.

Verifying Operation

Verifying Operation

What You'll Find In This Chapter

This chapter contains test procedures that verify the electrical performance of the GSM digital demodulator options (spectrum analyzer options 151 and 163), and the time-gated spectrum analysis card (spectrum analyzer option 105). It contains the following sections:

- Preparing for the verification tests.
- Gate delay accuracy and gate length accuracy.
- Gate card insertion loss.
- Phase error accuracy.
- Frequency error accuracy.
- The performance verification test record.

NOTE:

Options 151 and 163 are required to verify the phase and frequency error accuracy.

Preparing for the Verification Tests

Do these four things before beginning a verification test:

- 1 Turn on the spectrum analyzer and allow it to warm up for at least 30 minutes.
- 2 Familiarize yourself with basic HP 8590E- Series spectrum analyzer operation.
- 3 Perform the spectrum analyzer's self-calibration routines. Refer to the spectrum analyzer documentation for instructions. (Before performing the self-calibration routines, ensure that nothing is connected to the GATE TRIGGER INPUT connector. Otherwise, the self-calibration routine's results may not be valid.)
- 4 Read the rest of this section before you start any of the tests, and make a copy of the performance verification test record as described in "To record the test results."

The test equipment you will need

Table 9, "Recommended Test Equipment," on page 169 lists the recommended test equipment for the performance tests. Any equipment that meets the critical specifications given in the table can be substituted for the recommended model or models.

To record the test results

Within the verification procedure, there are places to enter the test results. In addition, the performance verification test record on page 186 has been provided at the end of the chapter. We recommend that you make a copy of the table, record the test results on the copy, and keep the copy for your calibration test records. This record could prove valuable in tracking gradual changes in test results over long periods of time.

Periodically verifying operation

The spectrum analyzer requires periodic verification of operation. Under most conditions of use, you should perform these verification tests once a year to ensure that the spectrum analyzer meets the specifications.

If the spectrum analyzer does not meet its specifications

- 1 Ensure that there is nothing connected to the spectrum analyzer's GATE TRIGGER INPUT connector.
- 2 Rerun the spectrum analyzer's frequency and amplitude self-calibration routines. See the spectrum analyzer documentation for more information.
- 3 Repeat the verification test.

If the spectrum analyzer continues to fail one or more of its specifications, complete any remaining tests and record the results on a copy of the performance verification test record, then return the spectrum analyzer with a copy of the completed test record to a Hewlett-Packard Sales and Service Office. Refer to the spectrum analyzer documentation for addresses and shipping instructions.

Recommended test equipment

Table 9 lists the recommended test equipment for performing the verification tests.

Table 9 Recommended Test Equipment

Instrument	Critical Specifications for Equipment Substitution	Recommended Model	Use*
Synthesized signal generator	Frequency range: 932 MHz to 1806 MHz Amplitude: 0 dBm Modulation Modes: FM, Pulse Phase Noise: -95 dBc at 1 kHz offset -115 dBc at 10 kHz offset -125 dBc at 100 kHz offset	HP 8657B Option 003	P
Synthesizer/ function generator	Frequency: 1 kHz Amplitude: 2 V pk-pk	HP 3325B	P
Synthesizer/ level generator	Frequency range: 50 MHz Amplitude range: +12 to -85 dBm Flatness: ± 0.15 dB Attenuator accuracy: ± 0.09 dB	HP 3335A	P,A,T
Oscilloscope	No substitute	HP 54501A	P,T
Universal counter	Time interval: 100 ns to 100 ms	HP 5316A	P
Pulse/function generator	Frequency: 100 Hz to 250 Hz Duty cycle: 13 - 50% Output: TTL square wave	HP 8116A	P
GSM Multiband Transmitter Measurement Personality	No substitute	HP 85727A	P
* P = Performance Test, A = Adjustment, T = Troubleshooting			

1. Verifying Gate Delay Accuracy and Gate Length Accuracy (Spectrum Analyzer Option 105 Only)

Specifications

Gate Delay Refer to Chapter 6, "Specifications and Characteristics", for specific values.

Gate Length Refer to Chapter 6, "Specifications and Characteristics", for specific values.

Description

The method used for measuring the gate length times is determined by the length of the gate. Shorter gate-length times are measured with an oscilloscope, and longer gate-length times are measured with a counter.

For shorter gate-length times, the output signal of a pulse generator is used to trigger the gate circuitry. To measure the gate delay, Δt markers are used. There is often up to 1 μs of jitter due to the 1 μs resolution of the gate delay clock. The "define measure" feature of the oscilloscope is used to measure and calculate the average length of the gate output automatically.

For longer gate-length times, a counter is used to measure the time period from the rising edge of the gate output to its falling edge. Because the gate-length time is equivalent to the clock accuracy of the spectrum analyzer, the gate-length time is compared to the specification for clock accuracy.

1. Verifying Gate Delay Accuracy and Gate Length Accuracy (Spectrum Analyzer Option 105 Only)

Equipment

- Universal counter HP 5316A
- Pulse/function generator HP 8116A
- Digitizing oscilloscope HP 54501A

Cables

- BNC, 120 cm (48 in) (four required) HP 10503A

Adapters

- BNC tee (m) (f) (f) (two required) 1250-0781

To determine small gate delay and gate length (jitter-term)

- 1 Connect the equipment as shown in Figure 68.

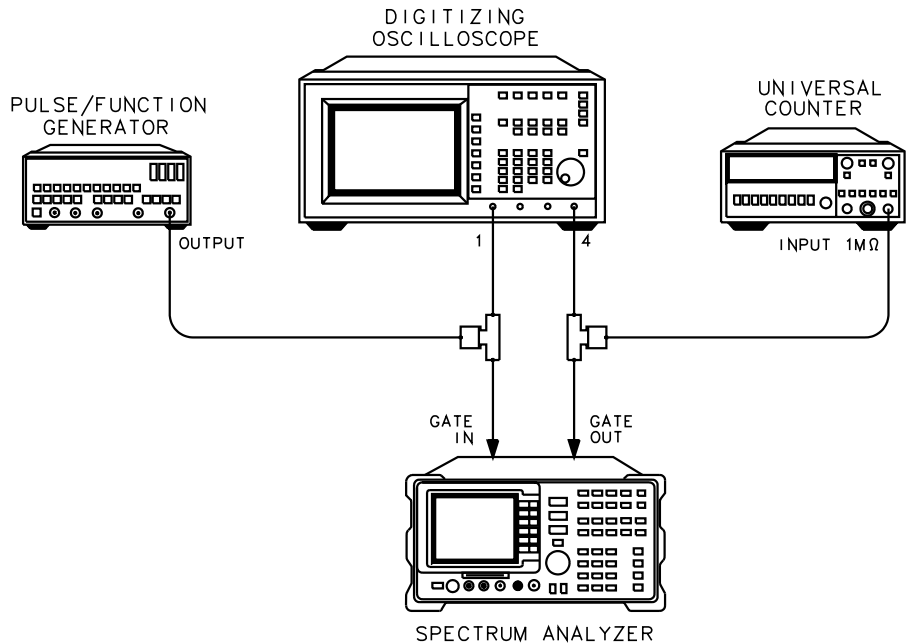

Figure 68

Gate Delay and Gate Length Test Setup

Verifying Operation

1. Verifying Gate Delay Accuracy and Gate Length Accuracy (Spectrum Analyzer Option 105 Only)

- 2 Press the following spectrum analyzer keys:

PRESET (wait for the completion of the preset routine)
SPAN, **ZERO SPAN**
SWEEP 20 **ms** **GATE ON OFF** (ON) **GATE MENU** **GATE DELAY**
1 **μs** **GATE LENGTH** 1 **μs**

- 3 Activate the square wave output on the function generator.

- 4 Set the pulse/function generator controls as follows:

MODE NORM
FRQ 100 Hz
DTY 50%
HIL 2.5 V
LOL 0.0 V

- 5 Press the following keys on the oscilloscope:

RECALL
CLEAR
DISPLAY
off frame axes grid highlight **grid**
connect dots off on highlight **on**
TRIG
source 1 2 3 4 highlight **4**
level 2 V
TIMEBASE 500 ns/div
CHAN
CHANNEL 1 2 3 4 off on highlight **CHANNEL 1 on**
set V/div to 1 V and offset to 2 V

..... highlight **CHANNEL 4 on**
set V/div to 1 V and offset to 3 V

DISPLAY
DISPLAY norm avg env highlight **env**

- 6 Press **CLEAR DISPLAY** on the oscilloscope. Wait for the trace to fill in, then press the following keys:

Δt ΔV
Δ markers off on highlight **on**
stop marker 0 μs

1. Verifying Gate Delay Accuracy and Gate Length Accuracy (Spectrum Analyzer Option 105 Only)

To record the minimum and maximum gate delay values

- 7 On the oscilloscope, press **start marker**. Use the knob to position the start marker on the upper trace on the right side of the oscilloscope display. See Figure 69.

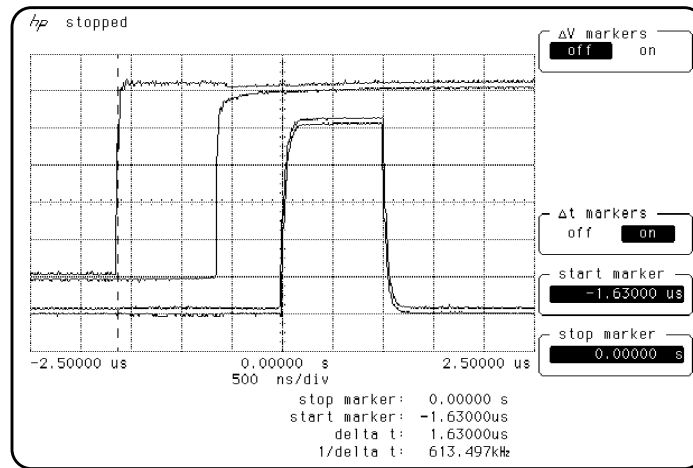

Figure 69 Oscilloscope Display of Minimum and Maximum Gate Delay Values

- 8 Record the Δt value of the start marker reading as the MIN gate delay.

MIN gate delay _____

(the expected value is greater than 0.0 μs , but less than 2.0 μs)

- 9 Use the oscilloscope knob to position the start marker on the edge of the left side of the upper trace.

- 10 Record the Δt value of the start marker reading as the MAX gate delay.

MAX gate delay _____

(the expected value is greater than 0.0 μs , but less than 2.0 μs)

1. Verifying Gate Delay Accuracy and Gate Length Accuracy (Spectrum Analyzer Option 105 Only)

To determine small gate length

11 Press the following keys on the oscilloscope:

BLUE, **+ WIDTH** 4

DEFINE MEAS

statistics off on highlight **on**

12 Read the average +width (4) displayed on the oscilloscope in the bottom right-hand annotation area.

13 Record this value as the 1 μ s gate length value.

1 μ s gate length _____

(the 1 μ s gate length minimum width should be greater than 800 ns and maximum width should be less than 1200 ns.

To determine large gate length (clock accuracy term)

14 Press the following spectrum analyzer keys:

SWEEP 150 **(ms)**, **GATE MENU**, **GATE DELAY** 10 **(ms)**,
GATE LENGTH 65 **(ms)**.

15 Set the universal counter controls as follows:

TI A \rightarrow B
GATE TIME delay mid-range
CHANNEL A rising edge, dc couple, SENSITIVITY mode
CHANNEL B. falling edge, dc couple, SENSITIVITY mode
COM A

16 Adjust LEVEL/SENS on the universal counter for best triggering.

17 Record the universal counter readout value as the 65 ms gate length.

65 ms gate length _____

(minimum gate length width should be greater than 64.99 ms and the maximum width should be less than 65.01 ms)

2. Verifying Gate Card Insertion Loss (Spectrum Analyzer Option 105 Only)

Specifications

- Additional amplitude error due to gate-on enabled

Log scale Refer to Chapter 6, "Specifications and Characteristics", for specific values.

Linear scale Refer to Chapter 6, "Specifications and Characteristics", for specific values.

Description

Use this procedure to verify that the insertion loss for the Option 105 card is within the specifications. See the specifications in Chapter 6, "Specifications and Characteristics", for the log and linear scale additional amplitude error due to gate-on enabled. The insertion loss is measured as follows:

- 1 HIGH SWEEP output on the spectrum analyzer is connected to GATE TRIGGER INPUT to provide a trigger signal for the gate circuitry.
- 2 The gate is turned off and a marker reading is taken.
- 3 The gate is then turned on and the synthesizer/level generator amplitude is adjusted to match the marker reading taken while the gate was off.

The difference between the two synthesizer/level generator readings is the measured insertion loss of the gate card.

Equipment

Synthesizer/level generator HP 3335A

Cables

BNC, 122 cm (48 in) (two required) HP 10503A

Additional Equipment for Option 001 Spectrum Analyzer

BNC cable, 75 Ω , 120 cm (48 in) HP part number 15525-80010

2. Verifying Gate Card Insertion Loss (Spectrum Analyzer Option 105 Only)

To determine the card insertion loss

- 1 Connect the equipment as shown in Figure 70. (For Option 001 spectrum analyzers, attach the 75 Ω cable to the spectrum analyzer's RF input connector rather than the 50 Ω cable.)

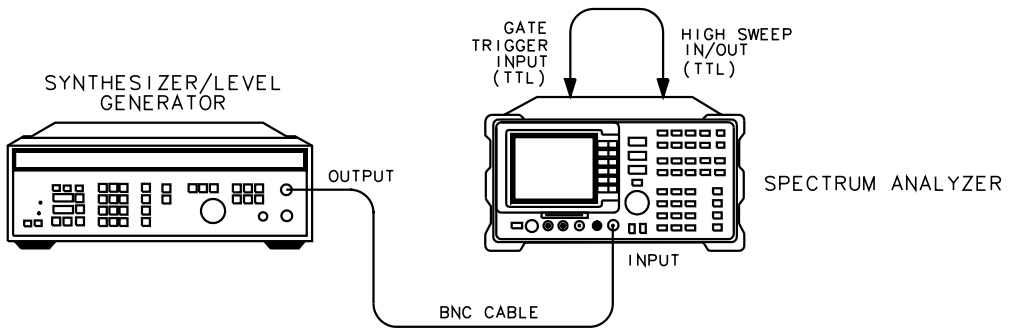

Figure 70 Gate Delay and Gate Length Test Setup

- 2 Set the synthesizer/level generator controls as follows:

FREQUENCY 50 MHz
 AMPTD INCR..... 0.01 dB
 AMPLITUDE -5 dBm

- 3 On the spectrum analyzer, press **PRESET**. Wait until preset is finished.
- 4 Press the following spectrum analyzer keys:

FREQUENCY 50 **MHz**
SPAN 1 **MHz**
BW 100 **KHz**
SWEEP 100 **ms**, **GATE ON OFF** (OFF), **GATE MENU**, **GATE DELAY**
 20 **ms**, **GATE LENGTH** 65 **ms**
PEAK SEARCH, **MARKER DELTA**
SWEEP, **GATE ON OFF** (ON)
PEAK SEARCH

- 5 Use the step INCR **▲** or **▼** key on the synthesizer/level generator to adjust the output amplitude for a spectrum analyzer MKR Δ reading of 0.0 ±0.05 dB.
 - 6 Record the amplitude displayed on the synthesizer/level generator as the synthesizer/level generator reading.
- synthesizer/level generator reading _____

2. Verifying Gate Card Insertion Loss (Spectrum Analyzer Option 105 Only)

- 7 Subtract the synthesizer/level generator reading you just recorded from -5.0 dBm. Record the result as the gate card insertion loss.

For example, if the synthesizer/level generator reading is -4.96 dBm, then the result is -0.04 dBm as shown below:

-5.0 dB minus the synthesizer reading is equal to the gate card insertion loss

$$(-5.0) - (-4.96) = -0.04 \text{ dBm}$$

gate card insertion loss _____

(the insertion loss should be between -0.3 dB and $+0.3$ dB)

3. Verifying Phase Error Accuracy (Spectrum Analyzer Option 151 and 163 Combination)

Specifications

Phase Error Refer to Chapter 6, "Specifications and Characteristics", for specific values.

Description

Use this procedure to verify that the phase error accuracy of the spectrum analyzer with options 151 and 163 installed is within specification. Phase errors are measured for both GSM900 and DCS1800 frequency ranges. The phase error accuracy is measured as follows:

- 1 A frequency and amplitude self-calibration is performed on the HP 8590E-Series spectrum analyzer to improve the accuracy of the spectrum analyzer.
- 2 A stable RF signal of known frequency is input to the spectrum analyzer. The frequency corresponds to a GSM channel transmitting a stream of data zeros.
- 3 The RF signal is FM modulated to provide an rms phase error of 1.8° and peak phase error of 2.55° .
- 4 The rms and peak phase errors are measured using the GSM Measurement Personality.
- 5 The results are compared with the specified phase errors.

If the measured rms phase error is between 0.8 and 2.8 degrees for an HP 8593E through HP 8596E, the product is within specification.

If the measured peak phase error is less than 6.55 degrees for an HP 8593E through HP 8596E, the product is within specification.

3. Verifying Phase Error Accuracy (Spectrum Analyzer Option 151 and 163 Combination)

Equipment

Synthesized signal generator	HP 8657B
Pulse generator	HP 8116A
Synthesized function generator	HP 3325B

Cables

BNC, 122 cm (48 in) (three required)	HP 10503A
BNC, 23 cm (9 in)	HP 10502A

Adapters

Type N (m) to BNC (f) (two required)	HP part number 1250-0780
BNC tee (m)(f)(f)	HP part number 1250-0781

To determine the phase error accuracy

- 1 Ensure that there is nothing connected to the spectrum analyzer GATE TRIGGER INPUT connector. Perform a frequency and amplitude self-calibration on the spectrum analyzer. This improves the accuracy of the spectrum analyzer. If necessary, refer to the “Getting Started” chapter of the *HP 8590E-Series Spectrum Analyzer User’s Guide* for a complete explanation of this procedure.
- 2 Connect the equipment as shown in Figure 71.

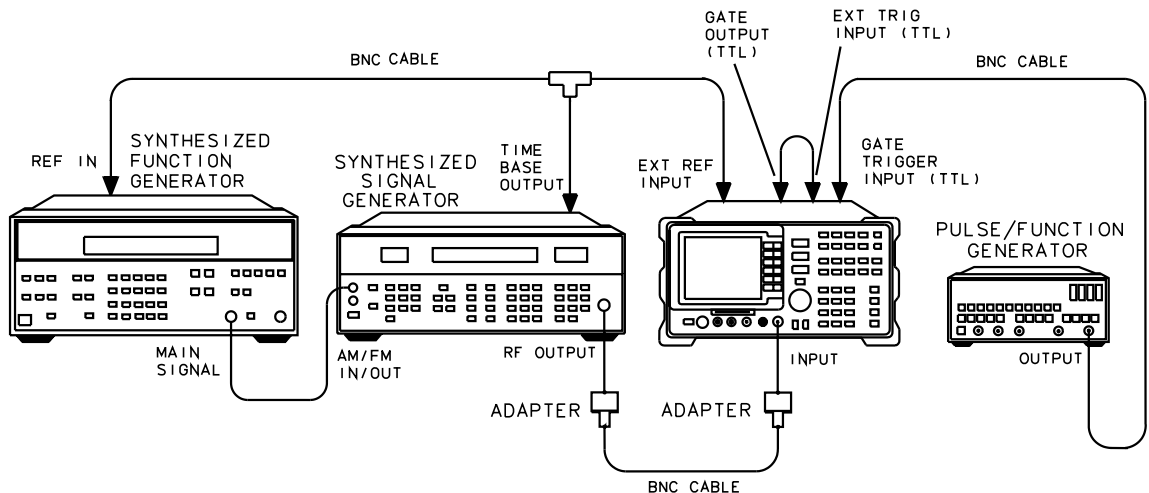

Figure 71

Phase Error Test Setup

Verifying Operation

3. Verifying Phase Error Accuracy (Spectrum Analyzer Option 151 and 163 Combination)

- 3 Press the following synthesized signal generator keys:

(SHIFT) 0 (Presets the HP 8657B)
(FREQ) 935.267708 (MHz)
(AMPTD) 0 (+dBm)
(EXT), (FM) 1 (kHz)

- 4 Press the following function generator keys:

(FREQ) 22.5 (kHz)
(AMPTD) 1.1 (VOLTS)

NOTE:

If necessary, adjust the function generator amplitude so that neither the HI EXT nor the LO EXT indicators on the synthesized signal generator are illuminated.

- 5 Set the pulse generator as follows:

Square wave output

MODE Normal
FRQ 250 Hz
DTY 50%
HIL 2.5 V
LOL 0.0 V

(Ensure the pulse generator output is enabled.)

- 6 Press the following HP 8590E-Series spectrum analyzer keys:

(PRESET)
GSM ANALYZER
PHYSICAL CHANNEL
ARFCN -1 (ENTER)
B M T ARFCN -1 CTR FREQ ARFCN 935.2 (MHz)
Previous Menu
Main Menu
More 1 of 2
Phase & Freq E:

- 7 Press PHASE FREQ NUMBER BURSTS 10 (ENTER)

NOTE:

The spectrum analyzer measurement status window may display MIDAMBLE BAD. This message is expected because you are measuring a continuous stream of data zeros. For true GSM signals a combination of ones and zeros is expected from the midamble.

- 8 Wait until the message **Peak Hold Measurement Completed** is displayed in the spectrum analyzer measurement status window. Record the rms

3. Verifying Phase Error Accuracy (Spectrum Analyzer Option 151 and 163 Combination)

and peak phase errors from the spectrum analyzer phase error window as the maximum GSM900 phase errors in the performance verification test record.

Set up for a DCS1800 channel frequency as follows:

- Press the following synthesized signal generator keys:

(FREQ) 1805.267708 **(MHZ)**

- Press the following HP 8590E-Series spectrum analyzer keys:

Physical Channel

B M T ARFCN

CTR FREQ ARFCN=-1 1805.2 **(MHz)**

Previous Menu , **Previous Menu**

REPEAT MEAS

- Wait until the message **Peak Hold Measurement Completed** is displayed in the spectrum analyzer measurement status window. Record the rms and peak phase errors from the spectrum analyzer phase error window as the maximum DCS1800 phase errors in the performance verification test record.

4. Verifying Frequency Error Accuracy (Spectrum Analyzer Option 151 and 163 Combination)

Specifications

Frequency

Error Refer to Chapter 6, "Specifications and Characteristics", for specific values.

Description

Use this procedure to verify that the frequency error accuracy of the spectrum analyzer with options 151 and 163 installed is within specification. Frequency errors are measured for both GSM900 and DCS1800 frequency ranges. The frequency error accuracy is measured as follows:

- 1 A frequency and amplitude self-calibration is performed on the HP 8590E-Series spectrum analyzer to improve the accuracy of the spectrum analyzer.
- 2 The mean frequency error and standard deviation are measured using the GSM Multiband Transmitter Measurement Personality. The measurements are made using both CW and pulsed signals.
- 3 The results are compared with the specified errors.

Equipment

Pulse generator. HP 8116A

Cables

BNC, 122 cm (48 in) (four required). HP 10503A

BNC, 23 cm (9 in) (one required) HP 10502A

Adapters

Type N (m) to BNC (f) (two required)HP part number 1250-0780

To determine the frequency error accuracy

- 1 Ensure that there is nothing connected to the spectrum analyzer GATE TRIGGER INPUT connector. Perform a frequency and amplitude self-calibration on the spectrum analyzer. This improves the accuracy of the

4. Verifying Frequency Error Accuracy (Spectrum Analyzer Option 151 and 163 Combination)

spectrum analyzer. If necessary, refer to the “Getting Started” chapter of the *HP 8590E-Series Spectrum Analyzer User’s Guide* for a complete explanation of this procedure.

- 2 Connect the equipment as shown in Figure 72.

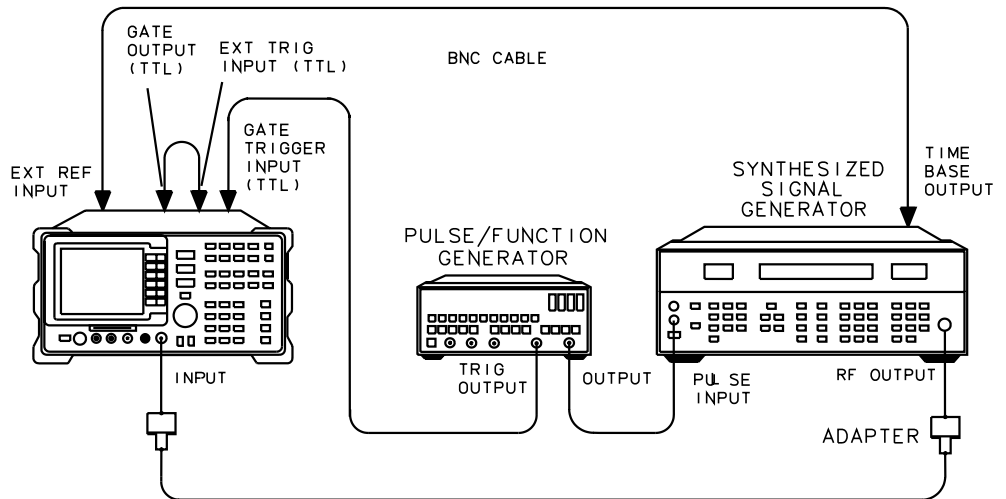

Figure 72 Phase Error Test Setup

- 3 Set the pulse generator as follows:

Square wave output

MODE Normal
 FRQ 217 Hz
 DTY 13%
 HIL 2.5 V
 LOL 0.0 V

(Ensure the pulse generator output is enabled.)

- 4 Press the following synthesized signal generator keys:

(SHIFT) 0 (Presets the HP 8657B)
 (FREQ) 935.267708 (MHz)
 (AMPTD) 0 (+dBm)

Verifying Operation

4. Verifying Frequency Error Accuracy (Spectrum Analyzer Option 151 and 163 Combination)

- 5 Press the following HP 8590E-Series spectrum analyzer keys:

```
(PRESET)
GSM ANALYZER
Physical Channel
ARFCN -1 (ENTER)
B M T ARFCN, CTR FREQ ARFCN=-1 935.2 (MHZ)
Previous Menu
Main Menu
More 1 of 2
Phase & Freq Err
PHASE FREQ
NUMBER BURSTS 100 (ENTER)
MEASURE AVG PKS (AVG)
```

NOTE:

The spectrum analyzer measurement status window may display MIDAMBLE BAD. This message is expected because you are measuring a continuous stream of data zeros. For true GSM signals a combination of ones and zeros is expected from the midamble.

- 6 Wait until the message **Averaged Measurement Completed** is displayed in the spectrum analyzer measurement status window. Record the frequency error from the spectrum analyzer frequency error window as the Mean GSM900 frequency error (CW) in the performance verification test record.
- 7 Press **STD DEV ON OFF** (ON)
- 8 Record the frequency error from the spectrum analyzer frequency error window as the GSM900 standard deviation (CW) in the performance verification test record.
- 9 Press **STD DEV ON OFF** (OFF)
- 10 Press the following synthesized signal generator keys:
(SHIFT) (AM)
- 11 Press the following HP 8590E-Series spectrum analyzer key:
(REPEAT MEAS)
- 12 Wait until the message **Averaged Measurement Completed** is displayed in the spectrum analyzer measurement status window. Record the frequency error from the spectrum analyzer frequency error window as the Mean GSM900 frequency error (pulsed) in the performance verification test record.
- 13 Press **STD DEV ON OFF** (ON)
- 14 Record the frequency error from the spectrum analyzer frequency error window as the GSM900 standard deviation (pulsed) in the performance verification test record.
- 15 Press **STD DEV ON OFF** (OFF)

4. Verifying Frequency Error Accuracy (Spectrum Analyzer Option 151 and 163 Combination)

Set up for a
DCS1800 channel

- 16 Press the following synthesized signal generator keys:

(FREQ) 1805.267708 **(MHZ)**

(SHIFT) **(AM)** **(OFF)**

- 17 Press the following HP 8590E-Series spectrum analyzer keys:

Physical Channel

B M T ARFCN

CTR FREQ ARFCN=-1 1805.2 **(MHZ)**

Previous Menu **Previous Menu**

REPEAT MEAS

- 18 Wait until the message **Averaged Measurement Completed** is displayed in the spectrum analyzer measurement status window. Record the frequency error from the spectrum analyzer frequency error window as the Mean DCS1800 frequency error (CW) in the performance verification test record.

- 19 Press **STD DEV ON OFF** (ON)

- 20 Record the frequency error from the spectrum analyzer frequency error window as the DCS1800 standard deviation (CW) in the performance verification test record.

- 21 Press **STD DEV ON OFF** (OFF)

- 22 Press the following synthesized signal generator keys:

(SHIFT) **(AM)**

- 23 Press the following HP 8590E-Series spectrum analyzer keys:

REPEAT MEAS

- 24 Wait until the message **Averaged Measurement Completed** is displayed in the spectrum analyzer measurement status window. Record the frequency error from the spectrum analyzer frequency error window as the Mean DCS1800 frequency error (pulsed) in the performance verification test record.

- 25 Press **STD DEV ON OFF** (ON)

- 26 Record the frequency error from the spectrum analyzer frequency error window as the DCS1800 standard deviation (pulsed) in the performance verification test record.

- 27 If the GSM900 option AD Demonstration personality was used for this performance test and the performance tests have been completed, you should delete it from the spectrum analyzer memory. For more information see “Purging Spectrum Analyzer DLP Memory” on page 21.

Performance Verification Test Record

The Performance Verification Test Record lists test specifications and acceptable limits. HP recommends that you make a copy of this table, record the complete test results on the copy of the performance verification test record, and keep the copy for your calibration test records. You may find that keeping a record of the calibration test records is helpful for tracking gradual changes in test results over long periods of time.

Address: _____ _____	Report No. _____		
	Date _____		
Model HP 8590E-Series spectrum analyzer with HP 85727A			
Serial No. _____	Customer _____		
Options _____	Tested by _____		
Firmware revision _____	Ambient temperature _____ °C		
Power mains line frequency _____ Hz(nominal)	Relative humidity _____ %		
Test Equipment Used:			
Description	Model No.	Trace No.	Cal Due Date
Synthesized signal generator	_____	_____	_____
Synthesizer/function generator	_____	_____	_____
Synthesizer/level generator	_____	_____	_____
Oscilloscope	_____	_____	_____
Universal counter	_____	_____	_____
Pulse/function generator	_____	_____	_____

Test No.	Test Description	Min	Results Measured	Max	Measurement Uncertainty
1.	Gate delay accuracy Gate length accuracy MIN gate delay MAX gate delay 65 ms gate length	0.0 μ s 0.0 μ s 64.99 ms	 _____ _____ _____ _____	2.0 μ s 2.0 μ s 65.01 ms	$\pm 0.011 \mu$ s $\pm 0.011 \mu$ s $\pm 0.434 \mu$ s
2.	Gate card insertion loss	-0.3 dB	 _____	+0.3 dB	± 0.092 dB
3.	Phase error accuracy Maximum GSM900 rms phase error Maximum DCS1800 rms phase error Maximum GSM900 peak phase error Maximum DCS1800 peak phase error	0.8° 0.8° 0° 0°	 _____ _____ _____ _____	2.8° 2.8° 6.55° 6.55°	$\pm 0.26^\circ$ $\pm 0.26^\circ$ $\pm 0.37^\circ$ $\pm 0.37^\circ$

Verifying Operation
Performance Verification Test Record

4.	Frequency error accuracy				
	Mean GSM900 frequency error (CW)	-7 Hz	_____	+7 Hz	N/A
	GSM900 standard deviation (CW)	0 Hz	_____	8 Hz	N/A
	Mean GSM900 frequency error (pulsed)	-10 Hz	_____	+10 Hz	N/A
	GSM900 standard deviation (pulsed)	0 Hz	_____	8 Hz	N/A
	Mean DCS1800 frequency error (CW)	-8 Hz	_____	+8 Hz	N/A
	DCS1800 standard deviation (CW)	0 Hz	_____	10 Hz	N/A
	Mean DCS1800 frequency error (pulsed)	-16 Hz	_____	+16 Hz	N/A
DCS1800 standard deviation (pulsed)	0 Hz	_____	10 Hz	N/A	

Specifications and Characteristics

General System Requirements

A positive or negative TTL transition signal is required to synchronize the measurement system with the transmitter under test. The synchronization signal must occur once per GSM frame. This trigger signal is required for carrier power, power versus time, output RF spectrum modulation, and phase and frequency error measurements.

GSM System Description

NOTE:

The *GSM System* refers to the following equipment configuration:

- HP 8593E, HP 8594E, HP 8595E or HP 8596E spectrum analyzer configured with:
 - Option 101 (fast time domain sweeps) *or* Options 151 and 163[‡] (Fast ADC & Digital Demodulator and GSM/DCS Firmware),
 - Option 105 (time gated spectrum analysis),
 - Option 004 (precision frequency reference) or equivalent external reference.
- ‡ Options 151 and 163 are required for phase and frequency error measurements.
- HP 85727A GSM Multiband Transmitter Measurement Personality
- HP 8498A Option 030 Attenuator Critical specifications for attenuator substitution:
 - Frequency range: dc to 18 GHz
 - Maximum input power: 25 W Avg, 500 W Peak
 - Attenuation Accuracy: ± 1.0 dB
 - Attenuation: 30 dB
 - SWR: 1.1
- HP 87405A Preamplifier Critical specifications for preamplifier substitution:
 - Frequency Range: 10 to 3000 MHz
 - Noise figure: < 7.5 dB
 - Gain: ≥ 22 dB
- Bandpass filter (GSM900 mobile station receive band) Critical specifications for BPF substitution:
 - Insertion loss: < 4 dB
 - Maximum ripple: ± 1 dB
 - Stopband: 90 dB at 880 MHz to 915 MHz
 - Passband: 925 MHz to 960 MHz
- Bandpass filter (GSM900 base station receive band) Critical specifications for BPF substitution:
 - Insertion loss: < 4 dB
 - Maximum ripple: ± 1 dB
 - Stopband: 90 dB at 925 MHz to 960 MHz
 - Passband: 880 MHz to 915 MHz

GSM System Description

- Bandpass filter (DCS1800 mobile station receive band) Critical specifications for BPF substitution:
 - Insertion loss: <4 dB
 - Maximum ripple: ± 1 dB
 - Stopband: 90 dB at 1710 MHz to 1785 MHz
 - Passband: 1805 MHz to 1880 MHz
- Bandpass filter (DCS1800 base station receive band) Critical specifications for BPF substitution:
 - Insertion loss: <4 dB
 - Maximum ripple: ± 1 dB
 - Stopband: 90 dB at 1805 MHz to 1880 MHz
 - Passband: 1710 MHz to 1785 MHz

GSM System Specifications

Maximum Safe Input Level

CAUTION:

Due to high input signal power, an external attenuator is required. System specification assumes 30 dB of fixed external attenuation for signals within the input power range. We recommend use of HP 8498A fixed attenuator with this GSM system.

CAUTION:

If you do not use the recommended attenuator, refer to the Maximum Safe Input Level specification in the Installation and Verification Manual for the spectrum analyzer in use.

With the recommended external attenuator, the system maximum input power is +46 dBm, 40 W. The system input power range is +43 dBm to +13 dBm. This corresponds to GSM base station Class 4 with a mean carrier power of 43 dBm +3/-0 dB.

Mean Transmitted Carrier Power

Accuracy ±2.3 dB
Relative Accuracy ±1.0 dB

NOTE:

This specification is derived from both the spectrum analyzer and HP 8498A option 030 external attenuator specifications.

Internal Frequency Reference (Opt. 004)

Aging ±1 x 10⁻⁷

Typical Measurement Speed: (Does not include set-up time)

	1 burst	10 bursts
Phase & Frequency Error	2 sec	20 sec
Carrier Power	3 sec	8 sec
Power vs. Time	4 sec	8 sec
Output RF Spectrum (Swept)	5 sec	24 sec
Spurious Emissions (TX Band)		40 sec
Intermodulation Attenuation		15 sec

Option 105 Time Gated Spectrum Analysis Specifications

NOTE:

When using Option 105 with the GSM System, the gate delay, gate length and additional amplitude error are specified.

Gate Delay	
Range	1 μ s to 65.535 ms
Resolution	1 μ s
Accuracy (from GATE TRIGGER INPUT to positive edge of GATE OUTPUT)	$\pm(1 \mu\text{s} + (0.01\% \times \text{GATE DELAY readout}))^*$
Gate Length	
Range	1 μ s to 65.535 ms
Resolution	1 μ s
Accuracy (from positive edge to negative edge of GATE OUTPUT)	$\pm(0.2 \mu\text{s} + (0.01\% \times \text{GATE LENGTH readout}))$
Gate Amplitude[‡]	
Additional Error	Log: ± 0.3 dB Linear: $\pm 0.4\%$ of reference level
* Up to 1 μ s jitter due to 1 μ s resolution of gate delay clock	
‡ With GATE ON enabled and triggered, CW Signal, and Peak Detector Mode	

GSM System Characteristics

Output RF Spectrum Dynamic Range (all input power levels)

Modulation Spectra

Offset from Carrier	Dynamic Range
Multiple and Single Mode	
100 kHz	30 dB
200 kHz	52 dB
250 kHz	60 dB
400 kHz	72 dB
600 kHz to 1800 kHz	75 dB
Swept Mode	
N/A	70 dB
Sensitivity in the Mobile Receive Band	
-87 dBm	

NOTE:

Sensitivity requires the use of the specified external bandpass filter centered on the receive band; spectrum analyzer input level <10 dBm.

Switching Transient Spectra

Offset from Carrier	Dynamic Range
Multiple and Single Mode	
400 kHz	72 dB
600 kHz	75 dB
1200 kHz	75 dB
1800 kHz	75 dB
Swept Mode	
N/A	70 dB

Spurious Emissions Characteristics

Sensitivity outside the Receive Band

NOTE:

The values listed below are referenced to the input of the external attenuator. The values apply when Max Hold and Peak Detector modes are active. They apply for signals offset more than 600 kHz from the carrier.

NOTE:

In Sample Detector and Clear Write modes, sensitivity is improved by approximately 13 dB.

Peak Power (dBm)	Resolution Bandwidth (kHz)							
	1	3	10	30	100	300	1000	3000
43	-42	-36	-30	-26	-21	-16	-11	-6
40	-52	-46	-40	-36	-31	-26	-21	-16
39	-52	-46	-40	-36	-31	-26	-21	-16
37	-52	-46	-40	-36	-31	-26	-21	-16
34	-52	-46	-40	-36	-31	-26	-21	-16
33	-52	-46	-40	-36	-31	-26	-21	-16
30	-62	-56	-50	-46	-41	-36	-31	-26
29	-62	-56	-50	-46	-41	-36	-31	-26
24	-62	-56	-50	-46	-41	-36	-31	-26
21	-62	-56	-50	-46	-41	-36	-31	-26
13	-72	-66	-60	-56	-51	-46	-41	-36

Sensitivity Inside the Receive Band

NOTE:

Receive band measurement system requires an input level less than -40 dBm.

Requires bandpass filter centered on receive band.

Requires the specified preamplifier between the input receive band bandpass filter and the spectrum analyzer.

Resolution Bandwidth	Displayed Average Noise Level
30 kHz	-107 dBm + insertion loss of BPF
100 kHz	-102 dBm + insertion loss of BPF
300 kHz	-97 dBm + insertion loss of BPF

Receive Band Amplitude Accuracy

Absolute Accuracy	± 4.9 dB
Relative Amplitude Accuracy	± 1.0 dB

NOTE:

This characteristic is derived from the Root Sum Squared (RSS) errors of the BPF, preamplifier, external attenuator, and the spectrum analyzer specifications.

Intermodulation Attenuation Characteristics

Outside Receive Band

Dynamic Range Outside of Receive Band (<6 GHz)	75 dB
Dynamic Range Outside of Receive Band (>6 GHz)	68 dB

NOTE:

Frequency range is from 100 kHz to 6 GHz.

Signals must be greater than 600 kHz from carrier.

Applies to all input power levels.

GSM specifications currently specify a measurement bandwidth of 30 kHz. A 4 or 5 pole 300 kHz synchronously tuned filter cannot resolve first intermodulation products at 800 kHz from the carrier or interfering signal. Improved selectivity and dynamic range can be achieved using a measurement bandwidth of 30 kHz.

Inside Receive Band

NOTE:

Receive band measurement system requires an input level less than -40 dBm.

Requires bandpass filter centered on receive band.

Requires the specified preamplifier between the input receive band bandpass filter and the spectrum analyzer.

In intra-base station tests, optimum spectrum analyzer spurious responses and distortion levels may be desired in the receive band. A mixer level of -40 dBm is optimal for TOI and spurious.

An external step attenuator (1 dB) can be used to optimize spectrum analyzer intermodulation performance and sensitivity.

Sensitivity in the Receive Band

Resolution Bandwidth	Displayed Average Noise Level
30 kHz	-107 dBm + insertion loss of BPF
100 kHz	-102 dBm + insertion loss of BPF
300 kHz	-97 dBm + insertion loss of BPF

Amplitude Accuracy

Absolute Amplitude Accuracy	±4.9 dB
Relative Amplitude Accuracy	±1.0 dB

NOTE:

This characteristic is derived from the RSS of the BPF, preamplifier, external attenuator, and the spectrum analyzer specifications.

Power Vs. Time

Relative Amplitude Accuracy	
(linear scale)	$\pm 3.0\%$
(log scale)	0.25 dB

Dynamic Range (all power levels)

Resolution Bandwidth	Dynamic Range
300 kHz	70 dB
1 MHz	68 dB

Displayed Time Resolution

Measurement	Displayed Time Resolution
Full timeslot	2.0 μs
Top 10 dB	1.6 μs
Rising Edge	0.2 μs
Falling Edge	0.2 μs

Centering Error (referenced to bit 13/14 edge or t0)

Measurement	RES BW 300 kHz	RES BW 1 MHz
Full Timeslot	$-4/+6.5 \mu\text{s}$	$-4/+5 \mu\text{s}$
Top 10 dB	$-4/+6.5 \mu\text{s}$	$-4/+5 \mu\text{s}$
Rising Edge	$-2.2/+5.9 \mu\text{s}$	$-2.2/+3.1 \mu\text{s}$
Falling Edge	$-2.2/+6 \mu\text{s}$	$-2.2/+3.2 \mu\text{s}$

Phase and Frequency Error

Phase Error (Phase Trajectory)

Range	±999°
Resolution	0.1°
Measurement Uncertainty^{a b}	1° rms 4° peak
Measurement Rate	1 reading/2.4 sec ^c

- For Measured readings greater than 1.5° rms.
- 0-55° C.
- 1 reading/sec with *Frequency Calibration* turned off.

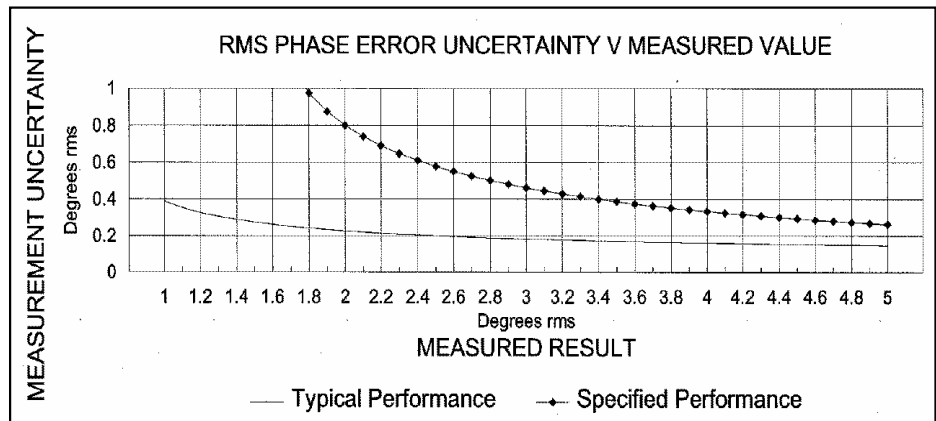

$$Uncertainty = Reading - \sqrt{Reading^2 - Analyzer\ Noise^2}$$

Frequency Error Measurement

	20 - 30° C	0 - 55° C
Noise (Standard Deviation)^a GSM 900 frequencies	7 Hz	9 Hz
Noise (Standard Deviation)^a DCS1800 frequencies	9 Hz	11 Hz
Mean CW^a	$\pm(6+\text{Ref Err}^b)$ Hz	$\pm(12+\text{Ref Err}^b)$ Hz
Mean Pulsed^a	$\pm(10+\text{Ref Err})$ Hz ^c	$\pm(12+\text{Ref Err})$ Hz ^c

- Based on 200 burst measurement
- Ref Err* is (frequency Reference Accuracy \times Carrier Frequency). Refer to “Frequency Reference Specifications” in the Spectrum Analyzer Calibration Guide.
- The Pulsed error component depends on the pulse shape. A ramp conforming to GSM specifications will give a smaller error than an abrupt pulse.

The total measurement uncertainty in individual readings is obtained by adding the mean and noise components.

The noise component is found by multiplying the standard deviation shown in the table by the factor appropriate to the confidence required. The noise has a Gaussian distribution. thus, for example, 99% of readings, which would be contained within $2.57 \times$ the standard deviation (obtained from standard statistical tables), will have a total uncertainty of:

$$\leq \pm(6 + 2.57 \times 7) = \pm 24\text{Hz}$$

absolute amplitude accuracy

The degree of correctness or uncertainty (expressed in either volts or dB power). It includes relative uncertainties plus calibrator uncertainty. For improved accuracy, some spectrum analyzers specify frequency response relative to the calibrator as well as relative to the midpoint between peak-to-peak extremes. Refer also to **relative amplitude accuracy**.

active function readout

The area of a display screen where the active function and its state are displayed. The active function is the one that was completed by the last key selection or remote-programming command.

active marker

The marker on a trace that can be repositioned by front-panel controls or programming commands.

active drive

The disk drive from which files are accessed by the controller used in the test system or test setup. It is sometimes called the current or default drive.

active trace

The trace (commonly A, B, or C) that is being swept (updated) with incoming signal information.

amplitude accuracy

The general uncertainty of a spectrum analyzer amplitude measurement, whether relative or absolute.

amplitude-left marker

This term identifies a second marker when the analyzer is in relative-marker mode. The position of the second marker is made relative to the position of the original marker. The marker readout in this mode represents the frequency and amplitude difference between the original marker and the second marker.

amplitude-right marker

This term represents a third marker when the analyzer is in relative-marker mode. The position of the third marker is made relative to the position of the original marker. The marker readout in this mode represents the frequency and amplitude difference between the original marker and the third marker.

ARFCN

The absolute RF channel number used in GSM measurements. The number denotes the nominal carrier frequency. ARFCN is sometimes referred to as the channel number.

ASCII

The acronym for American Standard Code for Information Interchange. It is an eight-part code (7 bits plus parity check) used for data (information) interchange. An ASCII value is a specific combination of bits ranging from 0 to 255 that represent characters in machine language that computers and controllers can understand.

attenuation

A general term used to denote a decrease of signal magnitude in transmission from one point to another. Attenuation may be expressed as a scalar ratio of the input to the output magnitude in decibels.

bandwidth selectivity

This is a measure of the analyzer's ability to resolve signals unequal in amplitude. It is the ratio of the 60 dB bandwidth to the 3 dB bandwidth for a given resolution filter (IF). Bandwidth selectivity indicates the slope of the filter skirts. Bandwidth selectivity is sometimes called shape factor.

battery-backed RAM

Random access memory (RAM) data retained by a battery. RAM memory cards can contain data that is maintained with a battery. Refer also to **nonvolatile memory**.

blank mode

This is an analyzer function that stores any active trace in the analyzer's reserved memory, and blanks the display. The stored trace may be either A, B, or C. Refer also to **reserved memory**.

B M T ARFCN

The abbreviation for bottom-, middle-, and top-ARFCNs. The terms refer to GSM measurement conditions. They denote nominal carrier frequencies located either in the lower, middle, and upper third of the allowed transmit spectrum.

broadband response

A signal whose spectrum is wider than the resolution bandwidth of a spectrum analyzer, and whose repetition frequency is lower than the bandwidth of the spectrum analyzer. It is a combination of signal and receiver characteristics that determines when a signal is classified as broadband. For refining incoming signal responses, select narrower spans and bandwidths. Refer also to **narrowband response**. The following checks can help verify whether or not the response is broadband:

- Change the resolution bandwidth. The displayed amplitude should change.
- Change the sweep time. The spacing of the responses on the display should change as you change the sweep time.
- Change the span. The spacing of the responses should not change. They should be independent of frequency span.
- Change the video bandwidth. If the video bandwidth is made narrower than the resolution bandwidth, the displayed amplitude of the responses should decrease.

BS (base station)

The GSM stationary hardware used to transmit and receive carrier signals. The base transceiver station connects many mobile stations simultaneously in a cell. Refer also to **cell**, **TX (transmit) band**, and **RX (receive) band**.

BSS (base station system)

A collection of base transceiver stations feeding to a common aerial.

BTS (base transceiver station)

Refer to **BS (base station)**.

burst

A GSM signal transmission. An RF pulse of a GMSK modulated carrier signal.

card reader

See **memory card**.

cell

The GSM term that identifies a geographic area served by a base station. The cell sizes and locations are determined by the geographic terrain and the base station power. Refer also to **GSM**.

channel number

The channel number used in GSM measurements. The number denotes the nominal carrier frequency. Refer also to **ARFCN**.

character set

The set of elementary symbols. These normally include both alpha and numeric codes, plus punctuation or any other symbol which may be read, stored, or written and used for organization, control, or representation of data.

carrier

A signal used to convey information through modulation of signal characteristics. Its power is usually the greatest among the signals present.

class

A term used to differentiate between mobile stations or base stations with differing output-power ratings.

clear-write mode

This is an analyzer function that clears the specified trace (A, B, or C) from the display, then sweeps (updates) the trace each time trigger conditions are met. When trigger conditions are met, the new input-signal data is displayed, then cleared, and the process begins again.

command

A set of instructions that are translated into instrument actions. The actions are usually made up of individual steps that together can execute an operation. Generally, for spectrum analyzers it is a code sequence that controls some operation of a spectrum analyzer. These codes can be keyed in via a controller, or computer. Refer also to **function**.

continuous sweep mode

The analyzer condition where traces are automatically updated each time trigger conditions are met.

CORR

A prompt displayed that indicates the measurement correction routine is in effect. It appears when correction factors are applied to measurement results.

correction factor

The factor by which a measurement reading is multiplied to correct for the effects of errors due to spectrum analyzer circuitry. This factor is the product of the ratio and phase-angle correction factors for the existing conditions of operation.

CRT persistence

An indication of the rate at which the image fades on the display. In analyzers that digitize the trace information (video) before writing it to the screen, the refresh rate is high enough to prevent any flicker in the display (therefore, short-persistence displays are used). Purely analog analyzers typically use long-persistence or variable-persistence displays because the refresh rate equals the sweep rate.

data line

The area on a display where user-selected characters are displayed. These characters are selected from the front-panel keys.

DANL

The abbreviation for displayed-average-noise-level of the spectrum analyzer. Refer also to **displayed average noise level**.

default

The factory-defined conditions, options, or parameters of an instrument. The default state may be changed by choosing key selections or writing programming commands to use other conditions.

delta marker

An analyzer mode in which a fixed reference marker is established, then a second active marker becomes available so it can be placed anywhere along the trace. A readout indicates the relative frequency separation and amplitude difference between the reference and active markers.

display detector mode

The manner in which analog, video information is processed prior to being digitized and stored in memory. Refer also to **negative peak**, **positive peak**, **quasi-peak detector**, and **sample**.

display dynamic range

The maximum dynamic range over which both the larger and smaller signal can be viewed simultaneously on the display. For analyzers with a maximum logarithmic display of 10 dB/division, the actual dynamic range may be greater than the display dynamic range. Refer also to **dynamic range**.

display range

The calibrated range of the display for a particular display mode or scale factor. Refer also to **linear display**, **log display**, and **scale factor**.

displayed average noise level

The noise level viewed on the analyzer's display after narrowing the video bandwidth setting enough to reduce the peak-to-peak noise fluctuations. The resulting noise display is essentially a straight line. Usually this term refers to the analyzer's own internally generated noise as a measure of sensitivity. It is typically specified in dBm under conditions of minimum resolution bandwidth and minimum input attenuation.

DLP

The abbreviation for downloadable program. A single programming command or a sequence of programming commands used to perform specific operations. DLPs can be made up of several functions, variables, and traces defined by the program creator. The DLP can be downloaded from one electronic storage medium into another and executed without a controller.

drift

The slow (relative to sweep time) change of signal position on the display as a result of a change in local oscillator frequency versus sweep voltage. While analyzer drift may require periodic re-tuning, it does not impair frequency resolution.

dynamic range

The power ratio (dB) between the smallest and largest signals simultaneously present at the input of an analyzer that can be measured with some degree of accuracy. Dynamic range generally refers to measurement of distortion or intermodulation products.

envelope detector

A detector circuit whose output follows the envelope, but not the instantaneous variation of its input signal. This detector is sometimes called a peak detector. In superheterodyne spectrum analyzers, the input to the envelope detector comes from the final IF, and the output is a video signal. When you put the spectrum analyzer in zero span, the envelope detector demodulates the input signal, and you can observe the modulating signal as a function of time on the display.

error message

A message displayed on the screen indicating missing or failed hardware, improper user operation, or other conditions that require additional attention. Generally, the requested action or operation cannot be completed until the condition is resolved.

external mixer

An independent mixer, usually having a waveguide input port, used to extend the frequency range of those spectrum analyzers designed to use them. The analyzer provides the local oscillator signal and mixer bias (if needed), then returns the mixing products to the analyzer's IF input.

external trigger signal

A signal level or signal edge that initiates a sweep of the analyzer. In the GSM Transmitter Measurements Personality, a TTL edge provided to the time gate input to make measurements synchronous with the frame rate.

FFT

The abbreviation for fast Fourier transform. It is a mathematical operation performed on a time-domain signal to yield the individual spectral components that constitute the signal. Refer also to **spectrum**.

firmware

An assembly made up of hardware and instruction code that are integrated to form a functional set which cannot be altered during normal operation. The instruction code, permanently installed in the circuitry of the instrument, is classified as ROM (read-only memory). The firmware determines the operating characteristics of the instrument or equipment. Each firmware version is identified by a revision code number, or date code.

flatness

The displayed amplitude variation corresponding to the tuned frequency range of the spectrum analyzer. Flatness of ± 1 dB indicates that maximum and minimum values of the analyzer's frequency response are less than 2 dB apart.

frame

A GSM time division multiple access (TDMA) frame is the span of time containing eight timeslots. A GSM TDMA frame occurs every 4.62 ms. Refer also to **timeslot**.

frequency accuracy

The uncertainty with which the frequency of a signal or spectral component is indicated, either in an absolute sense or relative to some other signal or spectral component. Absolute and relative frequency accuracies are specified independently.

frequency range

The range of frequencies which the spectrum analyzer performance is specified. The maximum frequency range of many microwave analyzers can be extended with the application of external mixers.

frequency resolution

The ability of a spectrum analyzer to separate closely spaced spectral components and display them individually. Resolution of equal amplitude components is determined by resolution bandwidth. Resolution of unequal amplitude signals is determined by resolution bandwidth and bandwidth selectivity.

frequency response

The peak-to-peak variation in the displayed signal amplitude over a specified center frequency range. Frequency response is typically specified in terms of \pm dB relative to the value midway between the extremes. It also may be specified relative to the calibrator signal.

frequency span

The magnitude of the displayed frequency component. Span is represented by the horizontal axis of the display. Generally, frequency span is given as the total span across the full display. Some analyzers represent frequency span (scan width) as a per-division value.

frequency stability

The stability of a frequency component to remain unchanged in frequency or amplitude over short- and long-term periods of time. Stability refers to the local oscillator's ability to remain fixed at a particular frequency over time. The sweep ramp that tunes the local oscillator influences where a signal appears on the display. Any long-term variation in local oscillator frequency (drift) with respect to the sweep ramp causes a signal to shift its horizontal position on the display slowly. Shorter-term local oscillator instability can appear as random FM or phase noise on an otherwise stable signal.

front-panel key

Keys, typically labeled, and located on the front panel of an instrument. The key labels identify the function of the key activities. Numeric keys and step keys are two examples of front-panel keys.

full span

A mode of operation in which the spectrum analyzer scans the entire frequency band of an analyzer.

function

The action or purpose which a specific item is intended to perform or serve. The spectrum analyzer contains functions that can be executed via front-panel key selections, or through programming commands. The characteristics of these functions are determined by the firmware in the instrument. In some cases, a DLP (downloadable program) execution of a function allows you to execute the function from front-panel key selections.

gain compression

The signal level at the input mixer of a spectrum analyzer where the displayed amplitude of the signal is a specific number of dB too low due just to mixer saturation. The signal level is generally specified for 1 dB or 0.5 dB compression and is usually between -3 dBm and -10 dBm.

GMSK

The abbreviation for Gaussian-Minimum-Shift-Keying. The term represents the digital signal modulation format for GSM systems. It is a variant of frequency-shift keying.

GSM

The abbreviation for Global Systems for Mobile Communications. GSM is a European digital-cellular radio standard and system. Frequency division multiplexing and time division multiple access (TDMA) are used. The data transmission format is GMSK modulation on a burst carrier. Refer also to **burst**, **GMSK** and **TDMA**.

hard copy

Information or data printed onto paper as opposed to its being stored on disk or in the instrument's memory.

harmonic distortion

Undesired frequency components added to signals as a result of nonlinear behavior of the device (for example, a mixer or an amplifier) through which signals pass. These unwanted components are harmonically related to the original signal.

harmonic mixing

The utilization of local oscillator harmonics generated in a mixer to extend the tuning range of a spectrum analyzer beyond the range achievable using just the local oscillator fundamental. The mathematical algorithm is:

$$F_{IN} = F_{LO} + F_{IF}$$

HP-IB

The abbreviation for Hewlett-Packard Interface Bus. It is a parallel interface that allows you to “daisy-chain” more than one device to a port on a computer or instrument. Interface protocol is defined in IEEE 488.2. It is equivalent to the industry standard GPIB.

idle mode

A GSM mobile station mode during which the RF output is temporarily turned off.

IF

The abbreviation for intermediate frequency. An IF frequency is a frequency to which a signal wave is shifted locally as an intermediate step in transmission or reception. On spectrum analyzers, this is the frequency resulting from conversion before demodulation.

IF gain/IF attenuation

A control that adjusts the vertical position of displayed signals without affecting the signal level at the input mixer. When changed, the value of the reference level is changed accordingly.

IF feedthrough

A condition that results in a rise in amplitude of the baseline trace. This occurs as a result of an input signal at the intermediate frequency (IF) passing through the input mixer. This is usually only a potential problem on non-preselected spectrum analyzers. The entire baseline trace rises because the signal is always at the IF. (Mixing with the local oscillator is not required.)

image response

A displayed signal that is actually twice the intermediate frequency (IF) away from the frequency indicated by the spectrum analyzer. For each harmonic of the local oscillator there is an image pair. One is below the local oscillator frequency by the IF and the other is above. Images usually only appear on non-preselected spectrum analyzers.

impedance

The apparent opposition in an electrical path to the flow of current. The specified nominal input impedance of a spectrum analyzer is stated for the input connector. The most common impedance for RF and microwave spectrum analyzers is 50Ω . However, 75Ω is typically used for cable television (CATV) work.

impulse bandwidth

The width of a rectangular filter that has the same peak voltage output as the actual analyzer filter. The impulse bandwidth of the synchronously-tuned, Gaussian-like resolution filters in the Hewlett-Packard spectrum analyzers is approximately 1.5 times the 3 dB bandwidth.

incidental FM

Undesired frequency modulation on the output of a device (for example a signal source or an amplifier) caused by or, incidental to, some other form of modulation, such as amplitude modulation.

input attenuator

An attenuator between the input connector and the first mixer of a spectrum analyzer (also called an RF attenuator). The input attenuator is used to adjust the signal level incident to the first mixer, and to prevent gain compression due to high-level or broadband signals. It is also used to set the dynamic range by controlling the degree of internally-generated distortion. For some analyzers, changing the input attenuator settings changes the vertical position of the signal on the display, which then changes the reference level accordingly. In Hewlett-Packard microprocessor-controlled spectrum analyzers, the IF gain is changed to compensate for changes in input attenuator settings. Because of this, the signals remain stationary on the display, and the reference level is not changed.

input impedance

The terminating impedance that the analyzer presents to the signal source. The nominal impedance for RF and microwave analyzers is usually 50Ω . For some systems, such as cable TV, 75Ω is standard. The degree of mismatch between the nominal and actual input impedance is called the VSWR (voltage standing wave ratio).

interface

The point at which different parts of a system interact. Also, the point at which operators and instruments interact.

intermodulation attenuation

A measure of the capability of the GSM transmitter to inhibit the generation of intermodulation distortion products.

intermodulation distortion

Undesired frequency components resulting from the interaction of two or more spectral components passing through a device having nonlinear behavior, such as a mixer or an amplifier. The undesired components are related to the fundamental components by sums and differences of the fundamentals and various harmonics. The algorithm is:

$$f_1 \pm f_2, 2 \times f_1 \pm f_2, 2 \times f_2 \pm f_1, 3 \times f_1 \pm 2 \times f_2, \text{ and so on}$$

intra-BSS intermodulation distortion

A measure of the capability of the GSM transmitter to inhibit the generation of intermodulation products caused by combining several transmitters.

limit line

A test limit made up of a series of line segments, positioned according to frequency or time, and amplitude, within the spectrum analyzer's measurement range. Two defined limit lines may be displayed simultaneously. One sets an upper test limit, the other sets a lower test limit. Trace data can be compared with the limit lines as the spectrum analyzer sweeps. If the trace data exceeds either the upper or lower limits, the spectrum analyzer displays a message or sounds a warning, indicating that the trace failed the test limits.

limit-line file

The user-memory file that contains the limit-line table entries. Limit lines are composed of frequency and amplitude components that make up a trace array and this data is stored in the file. The limit-line file feature is available on spectrum analyzers that are capable of limit-line operation. Refer also to **limit line**.

limit-line table

The line segments of a limit line are stored in the limit-line table. The table can be recalled to edit the line segments, then restored in the limit-line file. Refer also to **limit line**.

linear display

The display mode in which vertical deflection on the screen is directly proportional to the voltage of the input signal. The bottom line of the graticule represents 0 V; the top line represents the reference level. The reference level is a non-zero value characteristic to the spectrum analyzer model. On the HP 140 series analyzers, select a specific scale factor in volts per division. On newer models of spectrum analyzers, select the reference level. The scale factor becomes the reference level value divided by the number of graticule divisions. Although the display is linear, analyzers with microprocessors allow reference level and marker values to be indicated in dBm, dBmV, dBμV, volts, and in some cases, watts.

linear input level

The maximum input-signal level where gain compression does not occur. Refer also to **gain compression**.

LO

The abbreviation for local oscillator. The local oscillator output in a superheterodyne system is mixed with the received signal to produce a sum or difference equal to the intermediate frequency (IF) of the receiver. Refer also to **IF**.

LO feedthrough

The response that occurs on a spectrum analyzer's CRT when the first local oscillator frequency is equal to the first IF. The LO feedthrough is a 0 Hz marker with no error, so it can be used to improve the frequency accuracy of spectrum analyzers with nonsynthesized LO systems.

local oscillator emission or feadout

The presence of the local oscillator signal at the input of a spectrum analyzer. The level can be greater than 0 dBm on non-preselected spectrum analyzers, but it is usually less than -70 dBm on preselected spectrum analyzers.

log display

The display mode in which vertical deflection is a logarithmic function of the input-signal voltage. Log display is also referred to as logarithmic mode. The display calibration is set by selecting the value of the top graticule line (reference level), and scale factor in volts per division. On Hewlett-Packard analyzers, the bottom graticule line represents zero volts for scale factors of 10 dB/division or more. The bottom division, therefore, is not calibrated for those analyzers. Analyzers with microprocessors allow reference level and marker values to be indicated in dBm, dBmV, dB μ V, volts, and occasionally in watts. Nonmicroprocessor-based analyzers usually offer only one kind of unit, typically dBm.

marker

A visual indicator you can place anywhere along the displayed trace. A marker readout indicates the absolute value of the trace frequency and amplitude at the marked point. The amplitude value is displayed with the currently selected units. Refer also to **delta marker** and **noise marker**.

maximum input level

The maximum signal power that may be safely applied to the input of a spectrum analyzer. Typically 1 W (-30 dBm) for Hewlett-Packard spectrum analyzers.

MEAS UNCAL

A prompt displayed that indicates an uncalibrated measurement condition exists. It appears when instrument settings affect accuracy of measurement results to the extent that they no longer meet specifications.

measurement bandwidth

The resolution bandwidth required for a specific EMI measurement. For MIL-STD measurements, the resolution bandwidth is often determined by the tester with the approval of the contracting agency.

For commercial testing the measurement bandwidths required usually follow the recommendations of CISPR:

Band A (10 kHz to 150 kHz): 200 Hz

Band B (150 kHz to 30 MHz): 9 kHz

Band C and D (30 MHz to 1 GHz): 120 kHz

measurement range

The ratio, expressed in dB, of the maximum signal level that can be measured (usually the maximum safe input level) to the lowest achievable average noise level. This ratio is almost always much greater than can be realized in a single measurement. Refer also to **dynamic range**.

memory

A storage medium, device, or recording medium into which data can be stored and held until some later time, and from which the entire original data may be retrieved.

memory card

A small, credit-card-shaped memory device that can store data or programs. The programs are sometimes called personalities and give additional capabilities to your instrument. Typically, there is only one personality per memory card. Refer also to **personality**.

menu

The spectrum analyzer functions that appear on the display and are selected by pressing front-panel keys. These selections may evoke a series of other related functions that establish groups called menus.

midamble

A GSM pattern of 26 bits that are centered in the burst. The bits contain station identification information. Refer also to **burst**.

mixing mode

A description of the particular circumstance that creates a given response on a spectrum analyzer. The mixing mode, such as 1+, indicates the harmonic of the local oscillator used in the mixing process, and whether the input signal is above (+) or below (–) that harmonic.

MS (mobile station)

The GSM transmit and receive hardware of a single user. Mobile stations are free to move from cell to cell. Refer also to **cell**, **TX (transmit) band**, and **RX (receive) band**.

multiple responses

Two or more responses on a spectrum analyzer display from a single input signal. Multiple responses occur only when mixing modes overlap and the local oscillator is swept over a wide enough range to allow the input signal to mix on more than one mixing mode. Normally, this is not a problem with preselected analyzers.

narrowband response

A response measured under conditions in which there is only one spectral component at a time in the passband of a spectrum analyzer's resolution filter. This condition occurs for continuous wave signals and repetitive signals whose repetition rate is greater than about twice the resolution bandwidth of the analyzer. Note that a signal can have a spread spectrum and still be viewed in the narrowband mode on the spectrum analyzer. The same checks that were listed under **broadband response** are

used here but with different results:

- Change the frequency span. The frequency separation of the components remains unchanged.
- Change the resolution bandwidth. The amplitude of the responses does not change with resolution bandwidth changes (as long as the bandwidth remains narrow relative to the separation of the responses).
- Change the sweep time. The separation of the responses is independent of sweep time.
- Change the video bandwidth. The amplitude of the responses is unaffected by changes in video bandwidth.

negative peak

The minimum, instantaneous value of an incoming signal. On digital displays, each displayed point of the signal indicates the minimum value of the signal for that part of the frequency span or time interval represented by the point.

noise figure

The ratio, usually expressed in dB, of the signal-to-noise ratio at the input of a device (for example, a mixer or amplifier) to the signal-to-noise ratio at the output of the device.

noise marker

A marker whose readout represents the noise level in a 1 Hz noise power bandwidth. When the noise marker is selected, the sample display detection mode is activated, the values of a number of consecutive trace points about the marker (the number depends on the type of analyzer) are averaged, and this average value is normalized to an equivalent value in a 1 Hz noise power bandwidth. The normalization process accounts for detection and bandwidth plus the effect of the log amplifier when we select the log-display mode.

noise sidebands

Modulation sidebands that indicate the short-term instability of the local oscillator (primarily the first local oscillator) system of a spectrum analyzer. The modulating signal is noise, in the local oscillator circuit itself or in the local oscillator stabilizing circuit. The sidebands comprise a noise spectrum. The mixing process transfers any local oscillator instability to the mixing products. Thus the noise sidebands appear on any spectral component displayed on the analyzer above the broadband noise floor. Because the sidebands are noise, their level relative to a spectral component is a function of resolution bandwidth. Noise sidebands are typically specified in terms of dBc/Hz (amplitude in a 1 Hz bandwidth relative to the carrier) at a given offset from the carrier. The carrier being a spectral component viewed on the display.

nonvolatile memory

Memory data that is retained in the absence of an ac power source. This memory is typically retained with a battery. Refer also to **battery-backed RAM**.

operating system

A group of programs that control the general operation of a computer and its peripherals. The operating system assigns memory space, schedules jobs, and controls input and output.

parameter units

Standard units of measure, which include the following:

Measured Parameter	Unit Name	Unit Abbreviation
frequency	hertz	Hz
power level	decibel relative to milliwatts	dBm
power ratio	decibel	dB
voltage	volt	V
time	second	s
electrical current	ampere	A
impedance (resistance)	ohm	Ω

peak detection mode

The analyzer state where circuits calculate the peak value of a displayed signal. This value is determined by evaluating a series of measured values from an active trace.

peak detector

A detector that follows the peak or envelope of the signal applied to it. The standard detector in a spectrum analyzer is typically a peak detector. MIL-STD EMI measurements usually call for peak detection. Refer also to **quasi-peak detector** and **envelope detector**.

personality

Applications available on a memory card or other electronic media that extends the capability of an instrument for specific uses. Examples include digital radio personalities and cable TV personalities.

phase noise

Refer to **noise sidebands**.

physical channel

A GSM RF transmission channel. The channel is specified by current ARFCN and TN settings.

position units

The position unit describes the location of a point along the horizontal axis of a trace. Position unit values of a trace begin on the left-hand side of the graticule and increase to a predefined value (specific to the spectrum analyzer model) on the right-hand side of the graticule.

positive peak

The maximum, instantaneous value of an incoming signal. On digital displays, each displayed point of the signal indicates the maximum value of the signal for that part of the frequency span or time interval represented by the point.

preamplifier

An external, low-noise-figure amplifier that improves system (preamplifier/spectrum analyzer) sensitivity over that of the analyzer itself.

predefined trace

Trace A, B, or C of a spectrum analyzer. Refer also to **trace**.

preselector

A tunable bandpass filter placed ahead of a frequency converter, or mixer, of a spectrum analyzer. It tracks the appropriate mixing mode and passes signals of a desired frequency and reduces others. Preselectors are typically used only above 2 GHz. They essentially eliminate multiple and image responses and, for certain signal conditions, improve dynamic range.

quasi-peak detector

A detector circuit designed with time constants that give a weighted value to the amplitude of a detected signal. The displayed signal output is an indication of the degree to which the detected signal would impair the intelligibility of a desired signal. The time constants (rise, fall, average) for EMI purposes are based on the recommendations of CISPR that are in turn based on subjective tests. Interference limits for commercial EMI tests are often given in quasi-peak values.

query

Any spectrum analyzer programming command having the distinct function of returning a response. These commands may end with a question mark (?). Query commands return information either to the computer or to the analyzer display.

random-access memory

RAM (random-access memory) or read-write memory, is a storage area allowing access to any of its storage locations. Data can be written to or retrieved from RAM, but data storage is only temporary. When the power is removed, the information disappears. User-generated information appearing on a display is RAM data.

raster display

A television-like display in which the image is formed by scanning the electron beam rapidly across and slowly down the CRT face and gating the beam on as appropriate. The scanning rates are fast enough to produce a flicker-free display. Refer also to **vector display**.

read-only memory

ROM (read-only memory) that is encoded into the analyzer's firmware. The data can be accessed (read) only; it cannot be altered by the user.

RX (receive) band

The frequency range over which a GSM mobile station or base station can receive transmitted carrier signals. The mobile station receive band (RX band) frequencies range from 925 MHz to 960 MHz for GSM900 and 1805 MHz to 1880 MHz for DCS1800. The base station receive band frequencies range from 880 MHz to 915 MHz for GSM900 and 1710 MHz to 1785 MHz for DCS1800. Refer also to **TX (transmit) band**, **MS (mobile station)**, and **BS (base station)**.

reference level

The calibrated vertical position on the display used as a reference for amplitude measurement in which the amplitude of one signal is compared with the amplitude of another regardless of the absolute amplitude of either.

relative amplitude accuracy

The uncertainty of an amplitude measurement in which the amplitude of one signal is compared with the amplitude of another, regardless of the absolute amplitude of either. Distortion measurements are relative measurements. Contributors to uncertainty include frequency response and display fidelity and changes of input attenuation, IF gain, scale factor, and resolution bandwidth.

relative-marker mode

The active marker is positioned relative to the position of the reference marker. Marker readout shows amplitude, frequency, or time differences between the two markers.

reserved memory

An area used to store measurement results (trace A, B, or C), configuration information, correction factors, and selections made with front-panel keys or programming commands. The limit-line table contents are stored in reserved memory as well as the currently active key menu.

residual FM

The inherent short-term frequency instability of an oscillator in the absence of any other modulation. In the case of spectrum analyzers, you usually expand the definition to include the case where the local oscillator is swept. Residual FM is usually specified in peak-to-peak values, because they are most easily measured on the display, if they are visible at all.

residual responses

These are discrete responses seen on a spectrum analyzer display although no input signal is applied.

resolution

Refer to **frequency resolution**.

resolution bandwidth

The ability of a spectrum analyzer to display adjacent responses discretely (hertz, hertz decibel down). This term is used to identify the width of the resolution bandwidth filter of a spectrum analyzer at some level below the minimum insertion-loss point (maximum deflection point on the display). The 3 dB resolution bandwidth is specified; for others, it is the 6 dB resolution bandwidth.

sample

The instantaneous value of an incoming signal. On digital displays, each displayed point of the signal indicates the instantaneous value of the signal for that part of the frequency span or time interval represented by the point.

sample detector

A detector that yields the instantaneous value of the signal at the sample time.

scale factor

The per-division calibration of the vertical axis of the display.

scan (frequency span) linearity

The measured accuracy of the horizontal axis of the analyzer display. When two horizontal points are set with analyzer controls, then measured, the linearity is the calculated error between the two points compared with the analyzer settings.

sensitivity

The level of the smallest sinusoid that can be observed on a spectrum analyzer. This is usually under the optimized conditions of minimum resolution bandwidth, 0 dB input attenuation, and minimum video bandwidth. Hewlett-Packard defines sensitivity as the displayed average noise level. A sinusoid at that level appears to be about 2 dB above the noise.

serial prefix

Serial numbers that identify an instrument begin with a five-character prefix. The prefix in this case represents the version of firmware that particular instrument was shipped with.

SFH

The abbreviation for slow-frequency-hopping. SFH is the switching of a user signal through a sequence of carrier frequencies.

shape factor

Refer to **bandwidth selectivity**.

signal resolution

The ability of the spectrum analyzer to resolve two separate input signals. Closely spaced signals are more difficult to resolve than signals spaced far apart. Refer also to **resolution bandwidth** and **shape factor**.

signal identification

A routine, either manual or automatic, that identifies whether or not a particular response on the spectrum analyzer's display is from the mixing mode to which the display is calibrated. If the routine is automatic, the analyzer's tuning may change to show the signal in the correct mixing mode, or may tell you the signal's frequency. It may then give you the option of ignoring the signal or having the analyzer tune itself properly for the signal. This operation is not generally needed for preselected spectrum analyzers.

single-sweep mode

The spectrum analyzer sweeps once when trigger conditions are met. Each sweep is initiated by pressing an appropriate front-panel key, or by sending a programming command.

sinusoid

A wave whose electric-field vector is proportional to the sine (or cosine) of an angle that is a linear function of time, or distance or both.

softkey

Key labels displayed on a screen or monitor which are activated by mechanical keys surrounding the display, or located on a keyboard. Softkey selections usually evoke menus that are written into the program software. Front-panel key selections determine which menu (set of softkeys) appears on the display.

span

Span equals the stop frequency minus the start frequency. The span setting determines the horizontal-axis scale of the spectrum analyzer display.

span accuracy

The uncertainty of the indicated frequency separation of any two signals on the display.

spectral purity

Refer to **noise sidebands**.

spectral component

One of the sine waves comprising a spectrum.

spectrum

An array of sine waves differing in frequency and amplitude. They are properly related with respect to phase and, taken as a whole, constitute a particular time-domain signal.

spectrum analyzer

A device that effectively performs a Fourier transform and displays the individual spectral components (sine waves) that constitute a time-domain signal.

spurious emissions

The signals at frequencies other than those associated with the normal modulating and switching of the GSM carrier.

spurious response

The undesired responses that appear on a spectrum analyzer display as a result of the input signal. Internally generated distortion products are spurious responses, as are image and multiple responses. These can be either harmonic responses or nonharmonic responses. Harmonic responses are second, third, fourth, and so on, harmonics of the input signal. Nonharmonic responses are intermodulation and residual responses.

state-register

The area of user memory in the analyzer where measurement results and associated analyzer settings are stored.

stimulus-response mode

The operating state that allows a spectrum analyzer to make measurements similar to those of a network-analysis measurement system. Spectrum analyzers with this ability use tracking generator functions. The tracking generator may be an external instrument (stand-alone tracking generators) or designed into the analyzer hardware. Measurement results are displayed in a relative-amplitude scale resulting from a variation, plus or minus, from a reference (normalized) value stored in a trace.

stop/start frequency

Terms used in association with the stop and start points of the frequency measurement range. Together they determine the span of the measurement range.

syntax

The grammar rules that specify how commands must be structured for an operating system, programming language, or applications.

TDMA

The abbreviation for Time-Division-Multiple-Access. User signals are separated by the time they transmit, in addition to the frequency at which they transmit. GSM time multiplexes eight users onto one carrier frequency.

test limit

The acceptable results levels for any given measurement. The levels vary from country to country, and depend on the equipment being tested.

time-gate card

An option card (printed-circuit board) that can be installed into the spectrum analyzer card cage. The time-gate card permits the selection of discrete events in the time domain to be measured.

timeslot

A segment in a frame that is allocated 576.9 μ s for the user to transmit or receive information in the GSM system. Each timeslot permits 156.25 bits to be transmitted. The physical content of a timeslot is called a burst. Refer also to **frame** and **timeslot number**.

timeslot number

A timeslot number denotes the position of a transmission burst in a frame. There are eight timeslots that are numbered from 0 to 7. Refer also to **timeslot** and **frame**.

total power (GSM)

The sum of power values of the carrier signals that are active in the transmit band.

trace

A trace is made up of a series of data points containing frequency and amplitude information. The series of data points is often referred to as an array. Traces A, B, and C are the typical names of traces displayed on the analyzer. The number of traces is specific to the instrument.

transducer

A device that receives energy from one system, then supplies energy to another. The desired characteristics of the input energy appear at the output of the system. The energy being supplied by the device does not have to be of the same form as the energy the device received. As an example, a close-field probe receives energy from some source, then transmits the energy to a receiver, which then displays the information on the CRT.

transfer impedance

Ratio of the voltage output from a current probe to the current through a wire enclosed by the probe. Commonly expressed in decibels, referenced to 1Ω (dB Ω).

$$Z(\text{dB}\Omega) = V(\text{dB}\mu\text{V}) - I(\text{dB}\mu\text{A})$$

I = current through the wire

V = probe output voltage

Z = transfer impedance of the probe

TX (transmit) band

The frequency range over which a GSM mobile station or base station can transmit on carrier signals. The mobile station transmit band (TX band) frequencies range from 880 MHz to 915 MHz for GSM900 and 1710 MHz to 1785 MHz for DCS1800. The base station receive band frequencies range from 925 MHz to 960 MHz for GSM900 and 1805 MHz to 1880 MHz for DCS1800. Refer also to **RX (receive) band**, **MS (mobile station)**, and **BS (base station)**.

trigger delay

The delay of the start of a sweep after an external trigger signal is received. The delay is used to isolate GSM measurements within the desired timeslot, or sub-timeslot. Refer also to **timeslot** and **external trigger signal**.

units

Dimensions on the measured quantities. Units usually refer to amplitude quantities because they can be changed. In spectrum analyzers with microprocessors, available units are dBm (dB relative to 1 mW (milliwatt) dissipated in the nominal input impedance of the analyzer), dBmV (dB relative to 1 mV (millivolt)), dB μ V (dB relative to 1 μ V), volts, and in some analyzers watts.

update

To make existing information current; to bring information up to date.

upgrade

To improve the quality or extend the capability of an instrument or product. Enhancements to upgrade the product. These enhancements can then be documented in an update package.

vector display

The display type where the electron beam is directed so the image (consisting of trace, graticule, and annotation) is written directly onto the display face. It is not created from a series of dots as with the raster display.

video

A term describing the output of a spectrum analyzer's envelope detector. The frequency range extends from 0 Hz to a frequency that is typically well beyond the widest resolution bandwidth available in the analyzer. However, the ultimate bandwidth of the video chain is determined by the setting of the video filter.

video amplifier

A post-detection, dc-coupled amplifier that drives the vertical deflection plates of the display. Refer also to **video bandwidth** and **video filter**.

video average

The digital averaging of spectrum analyzer trace information. It is available only on analyzers with digital displays. Each point on the display is averaged independently and the average is computed based on the number of sweeps selected by the user. The averaging algorithm applies a factor to the amplitude value of a given point on the current sweep ($1/n$, where n is the number of the current sweep); applies another factor to the previously stored average [$(n - 1/n)$]; and combines the two for a current average. After the designated number of sweeps are completed, the factors remain constant, and the display becomes a running average.

video bandwidth

The cut-off frequency (3 dB point) of an adjustable low-pass filter in the video circuit. When the video bandwidth is equal to or less than the resolution bandwidth, the video circuit cannot fully respond to the more rapid fluctuations of the output of the envelope detector. The result is a smoothing of the trace, or a reduction in the peak-to-peak excursion, of broadband signals such as noise and pulsed RF when viewed in broadband mode. The degree of averaging or smoothing is a function of the ratio of the video bandwidth to the resolution bandwidth.

video filter

A post-detection, low-pass filter that determines the bandwidth of the video amplifier. It is used to average or smooth a trace. Refer also to **video bandwidth**.

zero span

The case in which a spectrum analyzer's local oscillator remains fixed at a given frequency so that the analyzer becomes a fixed-tuned receiver. In this state, the bandwidth is equal to the resolution bandwidth. Signal amplitude variations are displayed as a function of time. To avoid loss of signal information, the resolution bandwidth must be as wide as the signal bandwidth. To avoid any smoothing, the video bandwidth must be set wider than the resolution bandwidth.

A

accessing
 GSM mode, 29
 spectrum analyzer mode, 29
accessing GSM analyzer menus, 30
accessing the personality, 22
adding the personality, 21
AM/FM demodulation
 use with Option 105, 124
Amp Cor, 113
AMP COR ON OFF, 112, 115
amplitude correction
 amplitude coordinate, 115
 frequency coordinate, 115
 point, 113
 testing, 115
 using RECALL AMP COR, 115
 using SAVE AMP COR, 115
amplitude correction factors, 110
amplitude corrections
 creating, 112
 editing, 111
amplitude-correction factors, 110, 116
amplitude-correction functions, 113
amplitude-corrections
 creating, 111
analog+ display
 using, 109
annotation, 30
attenuation setting, 34

B

base-station, effects on physical channel
 settings, 36
battery
 changing the battery, 23

C

calibrating the analyzer, 19
card
 changing the battery, 23
card insertion loss, 175
characteristics, 189, 195
 intermodulation attenuation, 198
 output RF spectrum dynamic range, 195
 power vs time, 200
 spurious emissions, 196
combiner tuning measurement, 50

configuration for measurements, 34
connecting rear panel cables, 20
connections required, 19
contacting HP, 163
core program, 45
creating amplitude-correction factors, 111
creating limit lines, 96

D

default states, 37
default versus preset states, 37
definitions
 CRT text, vii
 hardkey, vii
 key, vii
 softkey, vii
deleting the personality from analyzer
 memory, 21
determining gate delay, 127
determining gate length, 127
disabled hardkeys, 32
display annotation, 30
downloading the DLP, 21
downloading the personality, 21

E

Edit Amp Cor, 113
EDIT DONE, 98, 106, 112, 115
Edit Limit, 99
Edit Lower, 100
Edit Lower limit line format, 103
Edit Mid/Delt, 100
Edit Mid/Delt limit line format, 104
Edit Up/Low, 100
Edit Up/Low limit line format, 103
Edit Upper, 97, 100
Edit Upper limit line format, 103
editing amplitude corrections, 111
editing limit lines, 98
equipment required, 18
error messages, 151, 162
Ext precision freq reference required error
 message, 153
External trigger required error message,
 153

F

Fast ADC card required

(opt 101 or opt 151) error message, 154
FLAT, 104
frequency accuracy, 182
front-panel keys, 32
functional check of Option 105, 142

G

gate card required
 (opt 105) error message, 154
gate control
 Option 105, 144
GATE CTL EDGE LVL
 operation, 144
gate delay
 determining the gate delay, 127
 setting gate delay outside the Gate
 Utility, 136
gate delay accuracy and gate length
 accuracy, 170
gate length
 determining the gate length, 127
 setting gate length outside the Gate
 Utility, 136
GATE TRIGGER INPUT connections,
 168
gate utility
 use of, 120
getting started, 19
GSM analyzer mode, 29
GSM analyzer vs spectrum analyzer
 hardkeys, 32
GSM measurements attenuation, 34
GSM mode
 accessing, 29
guidelines for using Option 105, 127

H

hanging up, spectrum analyzer, 147
hardkeys that are disabled, 32
how to use this manual, viii

I

input power requirement, 20
intermodulation attenuation
 characteristic, 198
intermodulation attenuation measurement,
 72
intermodulation products

for RX band, 77
for RX band intra-BSS, 84
for TX band, 73
for TX band intra-BSS, 82
intra-BSS intermodulation attenuation
measurement, 81
INVALID SYMTAB ENTRY
SYMTAB OVERFLOW error message,
155

L
license agreement, iii
LIMIT FAIL, 95
LIMIT LINES, 99
limit lines, 95
amplitude coordinate, 103
creating, 96, 98
displaying, 106
editing, 98
fixed, 99
frequency or time, 99
frequency or time coordinate, 103
relative, 99
segment number, 101
SEGMENT TYPE, 104
table format, 100
table type, 99
testing, 106
upper and lower, 107
using RECALL LIMIT, 106
using SAVE LIMIT, 106
LIMIT PASS, 95
limited warranty, iii, v
limit-line functions, 99, 106
LIMITS FIX REL, 97, 99
LIMITS FRQ TIME, 97, 99
LMT DISP Y N AUTO, 106
LMT TEST ON OFF, 98, 106
loading the GSM program, 21
loading the personality, 21
lower limit line, 101

M
main menu choices, 22
making measurements, 27
combiner tuning, 50
intermodulation attenuation, 72
intra-BSS intermodulation attenuation,

81
mean transmitted RF carrier power, 46
monitor TX band, 90
output RF spectrum, 55
output RF spectrum due to modulation
RX band, 62
phase and frequency error, 86
power steps, 48
power vs time, 52
spurious emissions, 65
marker counter
use with Option 105, 124
marker noise
use with Option 105, 124
mean transmitted carrier power
specification, 193
mean transmitted RF carrier power
measurement, 46
measurement
if the personality does not make a
measurement, 148
measurements
if the test results are not what you
expected, 148
making, 27
measurements and the memory card, 32
memory card
battery, 23
changing the battery, 23
write-protect switch, 24
menu access, 30
mid/delta limit-line format, 101
mobile station transmitter, spurious
emissions, 70
mobile-station, effects on physical channel
settings, 36
MODE key, 29
modulation
multiple-offset mode, 57
single-offset mode, 57
swept frequency mode, 58
monitor TX band measurement, 90

N
Newer firmware required
REV 931217 or later error message, 156
notation conventions, vii

O
operating Option 105, 123
option 050
verifying operation, 166
Option 101
used time gate Option 105, 123
Option 105
example of using time-gating, 126
functional check, 142
operation, 123
self-calibration routines, 140
spectrum analyzer settings, 126, 127
table of spectrum analyzer settings, 137
option 105
verifying operation, 166
option 151
verifying operation, 166
option 163
verifying operation, 166
options required, 18
output RF spectrum
due to modulation, 57
dynamic range characteristic, 195
measurement, 55

P
performance verification test record, 186
periodically verifying operation, 167
phase accuracy, 178
phase and frequency
error measurement, 86
phase and frequency error
specifications, 201
physical channel settings, 36
POINT, 104
power steps measurement, 48
power vs time
characteristic, 200
measurement, 52
preparing for the verification tests, 167
preset states, 37
preset versus default states, 37
problems
if the personality does not make a
measurement, 148
if the test results are not what you
expected, 148
pulse repetition interval, 126

-
- pulse width, 126
 - pulsed RF
 - using Option 105, 126
 - PURGE AMP COR, 113
 - PURGE LIMITS, 97, 99
 - purging the personality from analyzer memory, 21

 - Q**
 - quasi-peak detection
 - use with Option 105, 124

 - R**
 - RAM card, 23
 - rear panel connections, 20
 - receiver spurious emissions, 70
 - recommended test equipment table, 169
 - recommended test equipment for verification tests, 169
 - recording the verification test results, 167
 - required options, 18
 - RX band
 - intra-BSS intermodulation, 84
 - measuring intermodulation products, 77

 - S**
 - sample detection
 - use with Option 105, 124
 - SELECT AMPLITUD, 103, 115
 - SELECT DLT AMPL, 104
 - SELECT FREQ, 103, 115
 - SELECT LWR AMPL, 104
 - SELECT MID AMPL, 104
 - SELECT POINT, 113
 - SELECT SEGMENT, 101
 - SELECT UPR AMPL, 104
 - setting for measurements, 34
 - setting gate delay, 136
 - setting gate length, 136
 - SLOPE, 104
 - specifications, 189, 193
 - if the spectrum analyzer does not meet specifications, 168
 - mean transmitted carrier power, 193
 - phase and frequency error, 201
 - time gated spectrum analysis, 194
 - verifying operation, 166
 - spectrum analyzer mode
 - accessing, 29
 - spurious emissions
 - characteristics, 196
 - measurements, 65
 - mobile station transmitter, 70
 - receiver, 70
 - transmitter, 66

 - T**
 - test equipment for the verification tests, 167
 - test record, 186
 - test results, if the test results are not what you expected, 148
 - time gate
 - faster sweep times
 - Option 101, 123
 - time gated spectrum analysis
 - specification, 194
 - time-gated spectrum analyzer capability operation, 123
 - transients
 - multiple offset mode, 60
 - single offset mode, 60
 - swept frequency mode, 61
 - transmitter spurious emissions, 66
 - triggering, 39
 - using the HP 85902A, 40
 - using the HP 8922G, 42
 - using the unit under test, 39, 44
 - TX band
 - intra-BSS intermodulation, 82
 - measuring intermodulation products, 73

 - U**
 - upper and lower limit line, 101
 - upper and lower limit lines, 107
 - upper limit line, 100
 - using limit-line functions, 95
 - using the GATE CTL EDGE LVL, 144
 - using the level gate control, 144
 - using the personality, 22
 - using the self-calibration routines with Option 105, 140
 - using this manual, viii

 - V**
 - verification test
 - card insertion loss, 175
 - frequency accuracy, 182
 - gate delay accuracy and gate length accuracy, 170
 - phase accuracy, 178
 - record, 186
 - verification tests, how often they should be performed, 167
 - verifying operation, 166
 - how often, 167

 - W**
 - warranty, iii
 - windows
 - using, 118
 - write-protect switch, 24
-

